

P2897

Design Load (Safety Factor of 4)  
 (angles " 25°) - 550 Lbs (2.45 kN)  
 (angles > 25°) - 330 Lbs (1.47 kN)

Safety Factor 4  
 Torque: 13 Ft-Lbs (18 N·m)

Wt/100 pcs: 33 Lbs (15.0 kg)

P2784

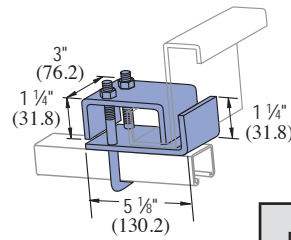

Part Number	For Use With	Load Lbs (kN)	Wt/100 pcs Lbs (kg)
P2784-1	P1000,	1,200	175
	P1100,	5.34	79.3
	P2000		
P2784-2	P1001,	1,200	179
	P1101,	5.34	81.1
	P2001		
P2784-3	P5001,	1,200	180
	P5501	5.34	81.5

PFL2-37

SWIFTGRIP

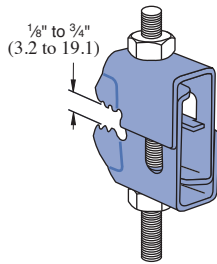

Designed to significantly reduce installation time, while offering greater performance than cast beam clamps, the Swiftgrip enables connection of drop rod to beam in one simple operation. Ideal for the suspension of building services equipment including heating, ventilating and air conditioning equipment; pipework; fire protection systems; electrical equipment and cable tray.

Available finish choices are Stainless Steel or Perma-Gold™ Industry Standard Yellow Dichromate.  
 Design Load is 540 Lbs (2.40 kN).  
 Safety Factor is 4  
 Torque is 8 Ft/Lbs (10.8 N·m)  
 Rod Size is 3/8" (9.5mm)

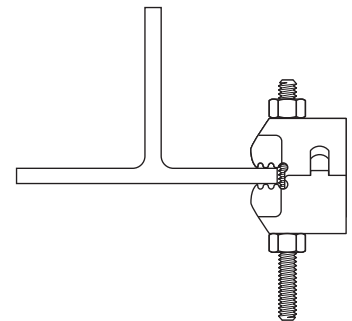

Wt/100 pcs: 26 Lbs (11.9 kg)

P2675

EG GR

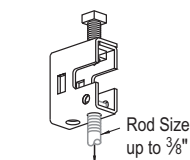
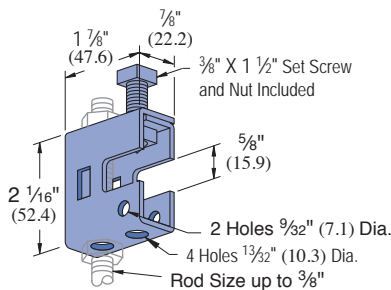

Design Load  
 250 Lbs (1.11 kN)

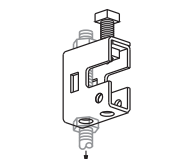

Design Load  
 150 Lbs (.67 kN)

Clamp Materials: .105" (2.7) thick steel.  
 Clamp P2675 is designed for light duty rod suspension. It also may be used with P3016-1024 or P3016-1420 nut as illustrated above for mounting insulators, etc.

Wt/100 pcs: 33 Lbs (15.0 kg)

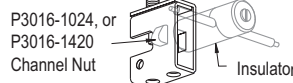

P8000, P8001 – JUNIOR DUCTILE IRON TOP BEAM CLAMP

**Material:** 3/8" and 1/2" rod sizes  
**Finish:** Plain (PL) and Electro-Galvanized (EG)  
**Function:** Structural attachment to top or bottom of metal beams, purlins, channel, or angle iron

**Features:**  
 • Set screw made of hardened steel  
 • Complies with Federal Specification A-A192A (Type 19) and MSS SP-69 (Type 19)



Part No. Plain & EG	Rod Size	Max Load Top Lbs*	Max Load Bottom Lbs*	Weight Lbs	W
P8000	3/8	500	250	0.33	7/8
P8001	1/2	950	760	0.34	1 1/16

NOTE: \*Max load may exceed allowable load for threaded rod size shown.

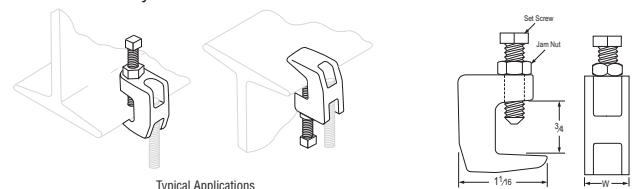

**Note:** When used for mechanical supports, load capacities of brackets, fittings and other supporting elements should be in compliance with the American Standard Code for Pressure Piping. Clamps are designed to be used with W, M, S & HP Shape beams, Standard C & Misc. MC Channels, Angles & Structural Tees. Clamps must be used in pairs where indicated. For beam clamps with HG finish, standard hardware is EG finish. For optional stainless steel hardware, please contact the factory for availability.



EG GR

### P2676

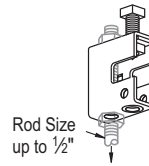
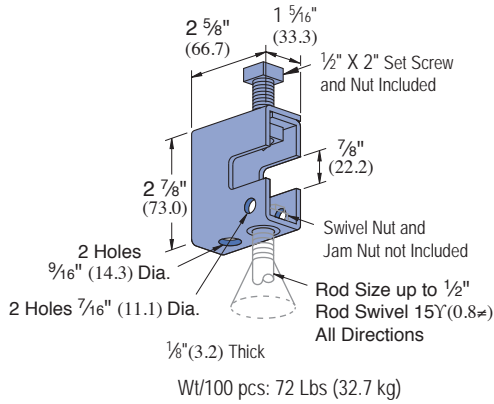

Design Load  
300 Lbs (1.33 kN)



Design Load  
500 Lbs (2.22 kN)

Clamp P2676 provides a means of rod suspension where a free swing of up to 15° (0.8π) is required. Clamp will accommodate 1/4" (6.4), 3/8" (9.5), or 1/2" (12.7) rods. Order swivel nuts P2679-4, -6, or -8 as required. Clamp may also be used with P2677 as illustrated in application drawings.

Clamp Materials: 1/8" (3.2) thick steel. Not available in SS or ST.

### P2898

UNIVERSAL BEAM CLAMP EG

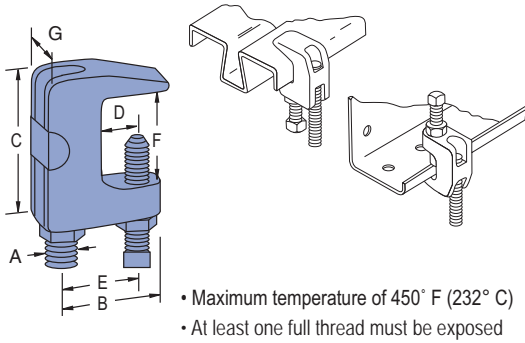

	A In	B In (mm)	C In (mm)	D In (mm)	E In (mm)	F In (mm)	G In (mm)	Max Load Lbs (kN)	Wt/100 pcs Lbs (kg)
P2898-37	3/8	1 25.4	1 1/2 38.1	1/2 12.7	1 25.4	3/4 19.1	7/8 22.2	400 1.78	33 15.0
P2898-50	1/2	1 1/4 25.4	1 1/2 38.1	1/2 12.7	1 25.4	3/4 19.1	7/8 22.2	500 2.22	33 15.0
P2898-62	5/8	1 1/2 38.1	1 1/2 38.1	1/2 12.7	1 25.4	3/4 19.1	1 25.4	600 2.67	22 10.0
P2898-75	3/4	1 3/4 47.6	1 3/4 44.5	5/8 15.9	1 1/8 34.9	1 25.4	1 1/4 31.8	800 3.56	88 40.0
P2898-87	7/8	2 50.8	1 3/4 44.5	5/8 15.9	1 1/2 38.1	1 25.4	1 1/4 31.8	1,200 5.34	79 35.9

### P2899

WIDE THROAT BEAM CLAMP EG

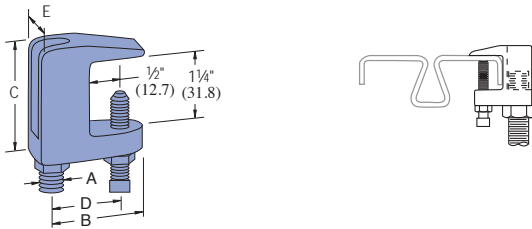

	Rod Size					Max. Load Lbs (kN)	Wt/100 pcs Lbs (kg)
	A in	B In (mm)	C In (mm)	D In (mm)	E In (mm)		
P2899-37	3/8	1 1/2 41.3	2 50.8	1 25.4	7/8 22.2	400 1.78	28 12.7
P2899-50	1/2	1 3/4 41.3	2 50.8	1 25.4	7/8 22.2	500 2.22	34 15.4
P2899-62	5/8	1 3/4 44.5	2 1/4 57.2	1 1/4 31.8	1 25.4	600 2.67	66 30.0
P2899-75	3/4	1 3/4 47.6	2 3/8 60.3	1 3/8 34.9	1 1/4 31.8	800 3.56	83 37.7

### P2682

EG

### P2677

EG

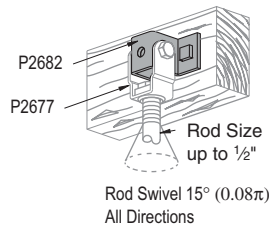
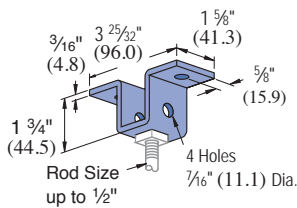

Rod Swivel 15° (0.08π)  
All Directions

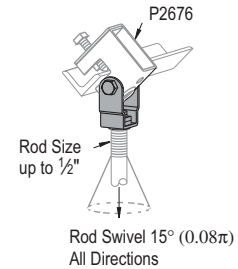
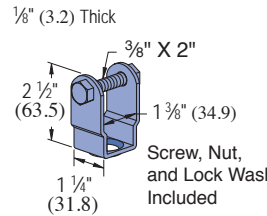

Rod Swivel 15° (0.08π)  
All Directions

Hanger clevis for up to 1/2" (12.7) rod suspension from wood ceilings. May also be used with P2677 as illustrated in application drawings.

Wt/100 pcs: 55 Lbs (24.9 kg)

### P2679-4, -6 & -8

SWIVEL NUT EG

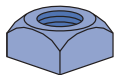

Part No.	Thread Size	Wt/100 pcs Lbs (kg)
P2679-4	1/4"-20	4 (1.8)
P2679-6	3/8"-16	5 (2.3)
P2679-8	1/2"-13	6 (2.7)

• Use w/P2676 and P2677.  
• Order size as required.

Clevis hanger to be used with P2676 or P2682 to provide angle adjustment and 15° (0.08 π) free swing for up to 1/2" (12.7) rod suspension. Order swivel nuts P2679-4, -6, or -8 as required.

Design Load  
500 Lbs (2.22 kN)

Wt/100 pcs: 30 Lbs (13.6 kg)

Note: When used for mechanical supports, load capacities of brackets, fittings and other supporting elements should be in compliance with the American Standard Code for Pressure Piping. Clamps are designed to be used with W, M, S & HP Shape beams, Standard C & Misc. MC Channels, Angles & Structural Tees. Clamps must be used in pairs where indicated. For beam clamps with HG finish, standard hardware is EG finish. For optional stainless steel hardware, please contact the factory for availability.

P2674

EG GR

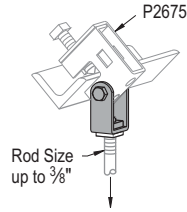
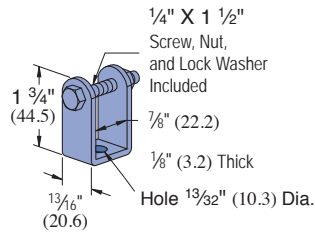

Clevis hanger to be used with P2675 to provide angle adjustment for up to 3/8" rod suspension as illustrated.

Design Load  
250 Lbs (1.11 kN)

Wt/100 pcs: 17 Lbs (7.7 kg)

P1640

EG GR

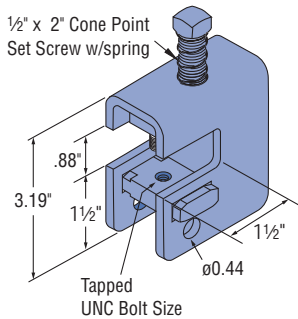

Part Number	Thread Size
P1640-025	1/4"-20
P1640-037	3/8"-16
P1640-050	1/2"-13

P2398S, P2401S, P2403S, P2405S

EG GR

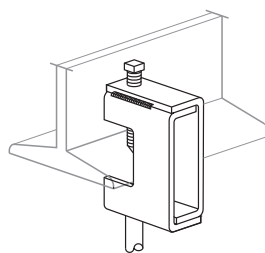
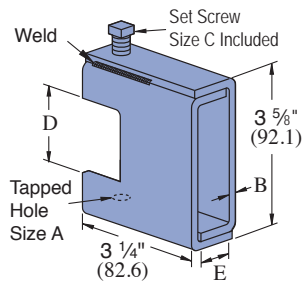

Weld is not continuous it is either 1 1/4" (31.8) - 1 3/4" (44) long or 2 spot welds. All welds are on the top and bottom.

For beams between 3/4" (19.1) to 1 5/8" (41.3) thick flanges.

Part Number	"A" In	"B" In (mm)	"C" In	"D" In (mm)	"E" In (mm)	Wt/100 pcs Lbs (kg)	Design Load Lbs (kN)
P2398S	1/4 - 20	3/8 3.2	3/8 x 2	1 1/2 42.1	7/8 22.2	109 49.4	800 3.56
P2401S	3/8 - 16	3/16 4.8	1/2 x 2	1 1/16 42.9	29/32 23.0	156 70.8	1,300 5.78
P2403S	1/2 - 13	1/4 6.4	1/2 x 2	1 1/16 42.9	15/16 23.8	201 91.2	1,900 8.45
P2405S	5/8 - 11	5/16 7.9	5/8 x 2	1 1/16 42.9	15/16 33.3	311 141.1	2,400 10.68

P1648S THRU P1653S

EG GR

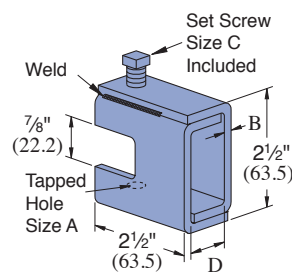

For beams under 7/8" (22.2) thick flange.

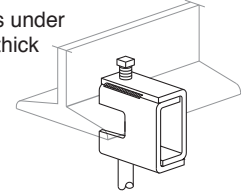

Weld is not continuous it is either 1 1/4" (31.8) - 1 3/4" (44.5) long or 2 spot welds. All welds are on the top and bottom.

Part Number	"A" In	"B" In (mm)	"C" In	"D" In (mm)	Wt/100 pcs Lbs (kg)	Design Load Lbs (kN)
P1648S	1/4 - 20	3/8 3.2	3/8 x 1 1/2	7/8 22.2	67 30.4	650 2.89
P1649S	5/16 - 18	3/8 3.2	3/8 x 1 1/2	7/8 22.2	67 30.4	650 2.89
P1650S	3/8 - 16	3/16 4.8	1/2 x 1 1/2	15/16 23.8	100 45.4	1,100 4.89
P1651S	1/2 - 13	1/4 6.4	1/2 x 1 1/2	15/16 23.8	130 59.0	1,600 7.12
P1652S	5/8 - 11	5/16 7.9	5/8 x 1 1/2	15/16 33.3	160 72.6	2,400 10.68
P1653S	3/4 - 10	5/16 7.9	5/8 x 1 1/2	15/16 33.3	160 72.6	2,400 10.68

P1654A THRU P1661A

RETAINER STRAP EG GR

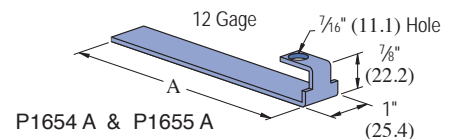
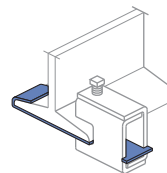

For beams under 7/8" (22.2) thick flange.

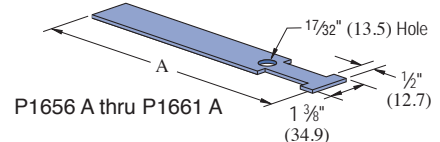

Strap Part Number	Flange Width In (mm)	"A" In (mm)	Wt/100 pcs Lbs (kg)	Beam Clamp Used With
P1654 A	6 152.4	7 177.8	25 11.3	P2675
P1655 A	9 228.6	10 254.0	34 15.4	P2675
P1656 A	6 152.4	9 228.6	35 15.9	P1648 S Thru P1651 S, P2398S, P2401S & P2403S
P1657 A	9 228.6	12 304.8	47 21.3	
P1658 A	12 304.8	15 381.0	59 26.8	
P1659 A	6 152.4	9 228.6	33 15.0	P2676
P1660 A	9 228.6	12 304.8	45 20.4	P2676
P1661 A	12 304.8	15 381.0	57 25.9	P2676

Note: When used for mechanical supports, load capacities of brackets, fittings and other supporting elements should be in compliance with the American Standard Code for Pressure Piping. Clamps are designed to be used with W, M, S & HP Shape beams, Standard C & Misc. MC Channels, Angles & Structural Tees. Clamps must be used in pairs where indicated. For beam clamps with HG finish, standard hardware is EG finish. For optional stainless steel hardware, please contact the factory for availability.



1 1/8" Channel

Telestrut

Nuts & Hardware

General Fittings

Pipe/Conduit Supports

Electrical Fittings

Concrete Inserts

Solar

### P1271S DF, EG, GR, HG

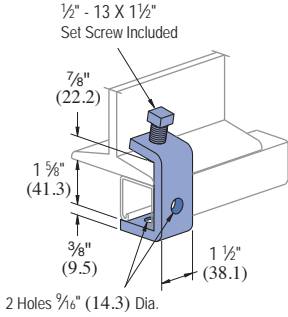

Note: Requires P1010 Channel Nut and bolt.

**Design Load Each**  
500 Lbs (2.22 kN)  
Use in Pairs Only

Wt/100 pcs: 95 Lbs (43.1 kg)

### P1796S EG GR HG

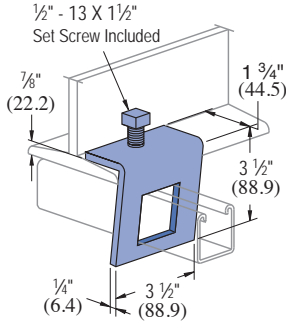

**Design Load Each**  
500 Lbs (2.22 kN)  
Use in Pairs Only

Wt/100 pcs: 91 Lbs (41.3 kg)

### P2824-6,-9,-12 EG GR HG

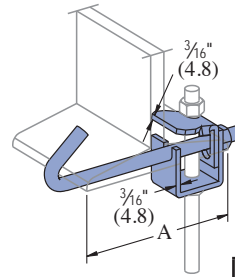

For use with Beams up to 3/4" (19.1) max flange thickness

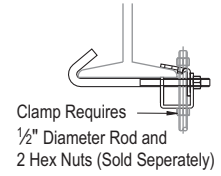

Part Number	"A" In (mm)	Wt/100 pcs Lbs (kg)	Design Load Lbs (kN)
P2824-6	2 1/2 - 6	125	500
	63.5 - 152.4	56.7	2.22
P2824-9	5 1/2 - 9	140	500
	139.7 - 228.6	63.5	2.22
P2824-12	8 1/2 - 12	171	500
	215.9 - 304.8	77.6	2.22

### P2785 DF, EG, GR, HG

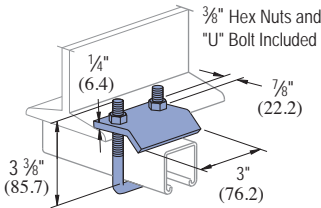

• For use with Beams up to 3/4" (19.1) Flanges and with Channels P1000, P1100, P2000, P3000, P3300, P3301, P4000, P4001, P4100, and P4101.

**Design Load Each**  
1000 Lbs (4.45 kN)  
Use in Pairs Only

Wt/100 pcs: 83 Lbs (37.6 kg)

### P2786 DF, EG, GR, HG

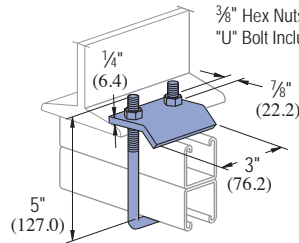

• For use with Beams up to 3/4" (19.1) Flanges and with Channels P1001, P1101, P2001, P3001, P5000, and P5500.

**Design Load Each**  
1000 Lbs (4.45 kN)  
Use in Pairs Only

Wt/100 pcs: 92 Lbs (41.7 kg)

### P2787 DF, EG, GR, HG

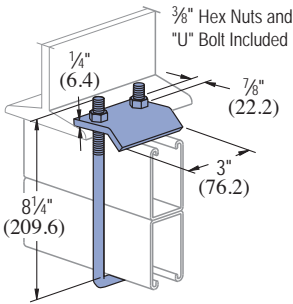

• For use with Beams up to 3/4" (19.1) Flanges and with Channels P5001 and P5501.

**Design Load Each**  
1000 Lbs (4.45 kN)  
Use in Pairs Only

Wt/100 pcs: 112 Lbs (50.8 kg)

### P2867 EG GR HG

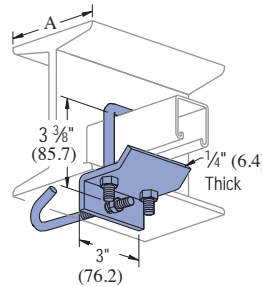

Part Number	Beam Size "A"	Wt/100 pcs Lbs (kg)
P2867	4"-6"	142 (64.4)
P2867-9	6"-9"	151 (68.5)
P2867-12	9"-12"	160 (72.6)
P2867-15	12"-15"	170 (77.1)
P2867-18	15"-18"	179 (81.2)

• Includes: "J" Bolt, "U" Bolt and Hex Nuts.  
• For use with Channels P1000, P1100, P2000, P3000, P3300, P3301, P4000, P4001, P4100, and P4101.

### P2867A EG GR HG

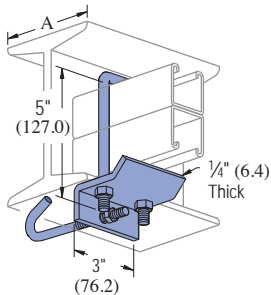

Part Number	Beam Size "A"	Wt/100 pcs Lbs (kg)
P2867A	4"-6"	151 (68.5)
P2867A-9	6"-9"	157 (71.2)
P2867A-12	9"-12"	166 (75.3)
P2867A-15	12"-15"	176 (79.8)
P2867A-18	15"-18"	185 (83.9)

• Includes: "J" Bolt, "U" Bolt and Hex Nuts.  
• For use with Channel P1001, P1101, P2001, P3001, P5000, and P5500.

### P2867B EG GR HG

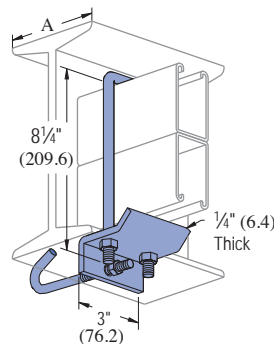

Part Number	Beam Size "A"	Wt/100 pcs Lbs (kg)
P2867B	4"-6"	161 (73.0)
P2867B-9	6"-9"	167 (75.7)
P2867B-12	9"-12"	176 (79.8)
P2867B-15	12"-15"	186 (84.4)
P2867B-18	15"-18"	195 (88.5)

• Includes: "J" Bolt, "U" Bolt and Hex Nuts.  
• For use with Channel P5001, and P5501.

**Note:** When used for mechanical supports, load capacities of brackets and fittings should be in compliance with the American Standard Code for Pressure Piping. Clamps are designed to be used with W, M, S & HP Shape beams, Standard C & Misc. MC Channels, Angles & Structural Tees. Clamps must be used in pairs where indicated. For beam clamps with HG finish, standard hardware is EG finish. For optional stainless steel hardware, please contact the factory for availability.

P2868

EG GR HG

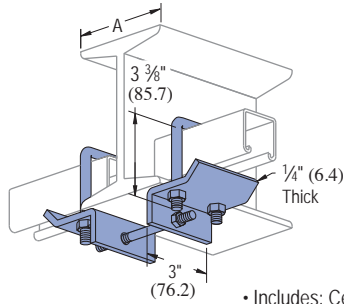

Part Number	Beam Size "A"	Wt/100 pcs Lbs (kg)
P2868	4"-6"	282 (127.9)
P2868-9	6"-9"	289 (131.1)
P2868-12	9"-12"	296 (134.3)
P2868-15	12"-15"	304 (137.9)
P2868-18	15"-18"	311 (141.1)

- Includes: Center Rod, "U" Bolts and Hex Nuts.
- For use with Channels P1000, P1100, P2000, P3000, P3300, P3301, P4000, P4001, P4100, and P4101.

P2868A

EG GR HG

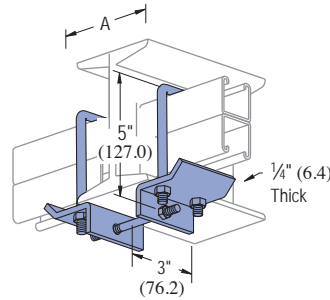

Part Number	Beam Size "A"	Wt/100 pcs Lbs (kg)
P2868A	4"-6"	300 (136.1)
P2868A-9	6"-9"	307 (139.3)
P2868A-12	9"-12"	314 (142.2)
P2868A-15	12"-15"	322 (146.1)
P2868A-18	15"-18"	329 (149.2)

- Includes: Center Rod, "U" Bolts and Hex Nuts.
- For use with Channels P1001, P1101, P2001, P3001, P5000, and P5500.

P2868B

EG GR HG

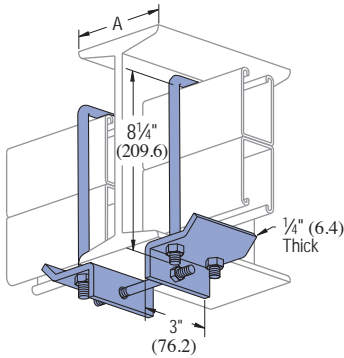

Part Number	Beam Size "A"	Wt/100 pcs Lbs (kg)
P2868B	4"-6"	320 (145.1)
P2868B-9	6"-9"	327 (148.3)
P2868B-12	9"-12"	334 (151.5)
P2868B-15	12"-15"	342 (155.1)
P2868B-18	15"-18"	349 (153.3)

- Includes: Center Rod, "U" Bolts and Hex Nuts.
- For use with Channels P5001, and P5501.

P2894

EG

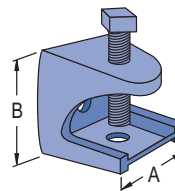

Material: Malleable Iron  
 7/8" Maximum Flange Thickness  
 Note: Tapped Hole on Top and Bottom

Part Number	Rod Size In	"A" In (mm)	"B" In (mm)	Load Ratings Lbs (kN)	Wt/100 pcs Lbs (kg)
P2894-25	1/4	1 1/8	1 1/4	150	23
		28.6	31.8	.67	10.4
P2894-37	3/8	2	2	350	95
		50.8	50.8	1.56	43.1
P2894-50	1/2	2 5/8	2 1/2	400	195
		66.7	63.5	1.78	88.5

P2893

EG

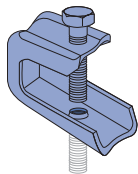

Material: Steel  
 Use With: 1/4" rod  
 Load Rating: 75 lbs. (.33 kN)

Wt/100 pcs: 14 lbs. (6.4 kg)

P2895

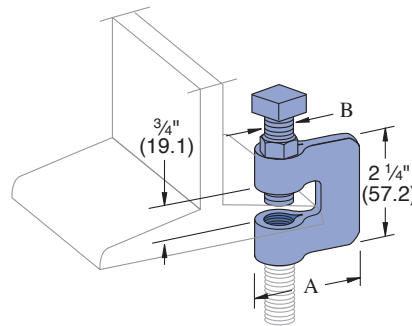

Material: Steel

Part Number	Rod Size In	"A" In (mm)	"B" In (mm)	Load Ratings Lbs (kN)	Wt/100 pcs Lbs (kg)
P2895-37	3/8	2 1/16	3/8	330	35
		58.7	9.5	1.47	15.9
P2895-50	1/2	2 1/4	1/2	380	41
		57.2	12.7	1.69	18.6
P2895-62	5/8	2 3/8	3/8	450	67
		60.3	15.9	2.00	30.4
P2895-75	3/4	2 1/4	1/2	500	72
		57.2	12.7	2.22	32.7

P2896

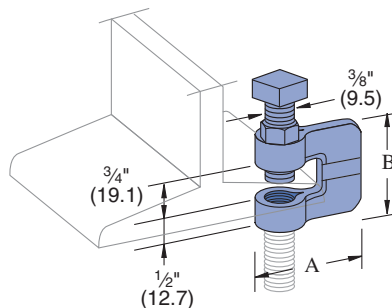

Material: Malleable Iron,  
 Steel Set Screw

Part Number	Rod Size In	"A" In (mm)	"B" In (mm)	Load Ratings Lbs (kN)	Wt/100 pcs Lbs (kg)
P2896-37	3/8	1 1/16	1 1/4	400	38
		42.9	44.5	1.78	17.2
P2896-50	1/2	1 3/32	1 1/4	400	52
		43.7	44.5	1.78	23.6
P2896-62	5/8	1 1/16	2	450	68
		49.2	50.8	2.00	30.8
P2896-75	3/4	2 1/32	2	600	128
		51.6	50.8	2.67	58.1

Note: When used for mechanical supports, load capacities of brackets, fittings and other supporting elements should be in compliance with the American Standard Code for Pressure Piping. Clamps are designed to be used with W, M, S & HP Shape beams, Standard C & Misc. MC Channels, Angles & Structural Tees. Clamps must be used in pairs where indicated. For beam clamps with HG finish, standard hardware is EG finish. For optional stainless steel hardware, please contact the factory for availability.



### P1386

DF, EG, GR, HG

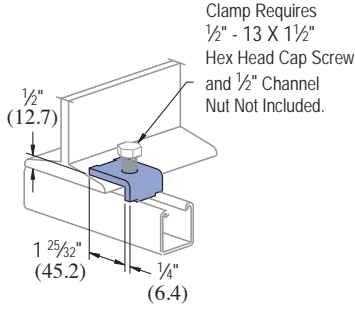

Clamp Requires 1/2" - 13 X 1 1/2" Hex Head Cap Screw and 1/2" Channel Nut Not Included.

Channel Style	Design Load Each (Use in Pairs Only) Lbs (kN)
P1000	600 2.67
P1100	500 2.22
P2000	450 2.00

Wt/100 pcs: 27 Lbs (12.2 kg)

### P1379S

EG GR HG

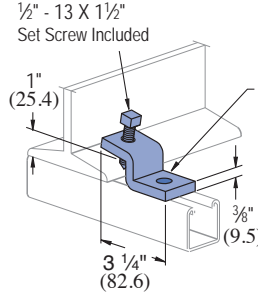

Clamp Requires 1/2" x 1 3/16" Hex Head Cap Screw and 1/2" Channel Nut Not Included.

Channel Style	Design Load Each (Use in Pairs Only) Lbs (kN)
P1000	600 2.67
P1100	500 2.22
P2000	450 2.00

Wt/100 pcs: 75 Lbs (34.0kg)

### P1272S, P1985S, P1986S

EG GR HG

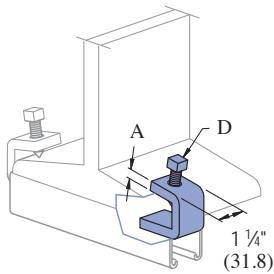

Part Number	"A" In (mm)	Flange Thickness In (mm)	"D" Set Screw Included	Wt/100 pcs Lbs (kg)	Design Load Per Pair (Use in Pairs Only) Lbs (kN)
P1272S	1/4 6.4	Up to 3/4 Up to 19.1	3/8-16 x 1 1/2	39 17.7	450 2.00
P1985S	3/8 9.5	Up to 3/4 Up to 19.1	1/2-13 x 1 1/2	62 28.1	1,000 4.45
P1986S	3/8 9.5	7/8 to 2 22.2 - 50.8	1/2-13 x 1 1/2	74 33.6	900 4.00

### P3087

COLUMN INSERT

EG

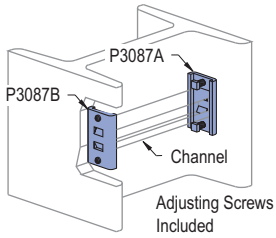

Channel Part Number	Design Pull Out Load Lbs (kN)	Design Slip Load Lbs (kN)
P1000	1,000 4.45	800 3.56
P1100	700 3.34	500 2.22
P2000	500 2.22	300 1.33

Safety factor of 3.

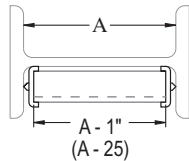

Wt/100 pcs: 136 Lbs (61.7 kg)

- Adjusting Screws Included.
- Unistrut channel not included.
- Part number P3087 consists of:
  - (1) piece P3087A,
  - (1) piece P3087B and
  - (2) set screws, 3/8" Dia.

### P3088

COLUMN INSERT

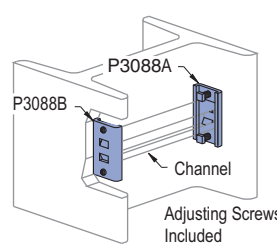

Channel Part Number	Design Pull Out Load Lbs (kN)	Design Slip Load Lbs (kN)
P3300	1,000 4.45	800 3.56
P4100	700 3.11	500 2.22
P4000	500 2.22	300 1.33

Safety factor of 3.

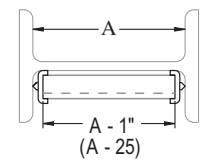

Wt/100 pcs: 120 Lbs (54.4 kg)

- Adjusting Screws Included.
- Unistrut channel not included.
- Part number P3088 consists of:
  - (1) piece P3088A,
  - (1) piece P3088B and
  - (2) set screws, 3/8" Dia.

### PLLC025

FLANGE CLAMP

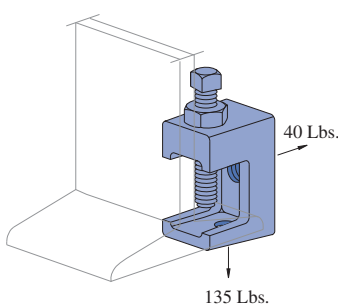

Cup point set screw and lock nut included.

Set Screw Torque = 3 Ft-Lb  
Lock Nut Torque = 3.5 Ft-Lb

X, Y are threaded holes.

Part Number	Rod Size	"Z" Set Screw Size	Wt/100 pcs Lbs (kg)
PLLC025	1/4"	1/4"	16 (7.3)

Part Number	Dimensions				
	"S" In (mm)	"T" In (mm)	"U" In (mm)	"V", "W" In (mm)	"X", "Y" In
PLLC025	5/8 15.9	1 25.4	1 1/16 36.5	3/4 19.1	1/4 X 20

Material: Malleable Iron.

**Note:** When used for mechanical supports, load capacities of brackets, fittings and other supporting elements should be in compliance with the American Standard Code for Pressure Piping. Clamps are designed to be used with W, M, S & HP Shape beams, Standard C & Misc. MC Channels, Angles & Structural Tees. Clamps must be used in pairs where indicated. For beam clamps with HG finish, standard hardware is EG finish. For optional stainless steel hardware, please contact the factory for availability.

PFL037 THRU PFL050T

FLANGE CLAMP

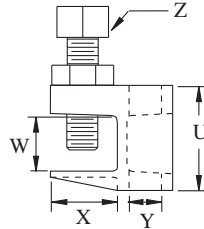
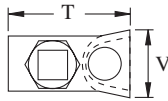
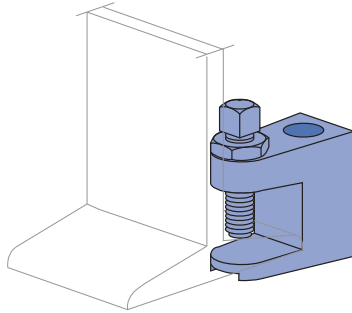

Material: Malleable Iron.

Cup point set screw and lock nut included.

Set Screw Torque = 6 Ft-Lb  
Lock Nut Torque = 16 Ft-Lb

Safety Factor: 4

Part Number	Type of Hole	Rod Size	"Z" Set Screw Size	Wt/100 pcs Lbs (kg)	Max. Allowable Load Lbs (kN)
PFL037	Clear	3/8"	3/8"	28 (12.7)	540 (2.40)
PFL037T	Tapped	3/8"	3/8"	28 (12.7)	540 (2.40)
PFL050	Clear	1/2"	3/8"	40 (18.1)	700 (3.11)
PFL050T	Tapped	1/2"	3/8"	40 (18.1)	700 (3.11)

Part Number	Dimensions					
	"T" In (mm)	"U" In (mm)	"V" In (mm)	"W" In (mm)	"X" In (mm)	"Y" In (mm)
PFL037	1 1/16	1 1/16	7/8	3/4	1	7/16
	42.9	39.7	22.2	19.1	25.4	11.1
PFL037T	1 1/16	1 1/16	7/8	3/4	1	3/8 Tapped Hole
	42.9	39.7	22.2	19.1	25.4	
PFL050	2	1 23/32	1	29/32	1 1/32	9/16
	50.8	43.7	25.4	23.0	27.8	14.3
PFL050T	2	1 23/32	1	29/32	1 1/32	1/2 Tapped Hole
	50.8	43.7	25.4	23.0	27.8	

PLF3037 THRU PLF3075

FLANGE CLAMP

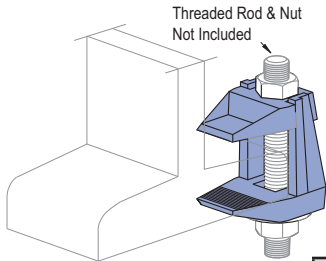

Threaded Rod & Nut Not Included

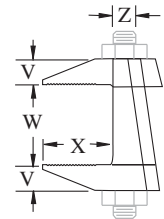
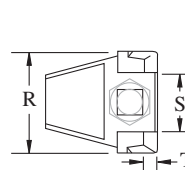

Safety Factor: 4

Material: Malleable Iron.

Part Number	Rod Size	Wt/100 pcs Lbs (kg)	Max. Allowable Load Lbs (kN)	Torque Ft-Lbs
PLF3037	3/8"	53 24	270 1.20	15
PLF3050	1/2"	91 41	450 2.00	29
PLF3062	5/8"	186 84	900 4.00	69
PLF3075	3/4"	334 152	1,350 6.01	130

Part Number	Dimensions					
	"X" In (mm)	"W" In (mm)	"V" In (mm)	"T" In (mm)	"R" In (mm)	"S" In (mm)
PLF3037	1	0 - 1 1/16	3/8	5/32	1 1/2	7/8
	25.4	0 - 30.2	9.5	7.1	38.1	22.2
PLF3050	1 1/2	0 - 1 1/16	1/2	1 1/32	1 13/16	1 1/32
	34.9	0 - 39.7	12.7	8.7	49.2	29.4
PLF3062	1 13/16	0 - 2 3/16	5/8	1/2	2 11/32	1 1/16
	46.0	0 - 55.6	15.9	12.7	59.5	36.5
PLF3075	2 3/16	0 - 1 3/4	3/4	5/8	3	1 3/4
	55.6	0 - 44.5	19.1	15.9	76.2	44.5

PLF9037 THRU PLF9100

FLANGE CLAMP

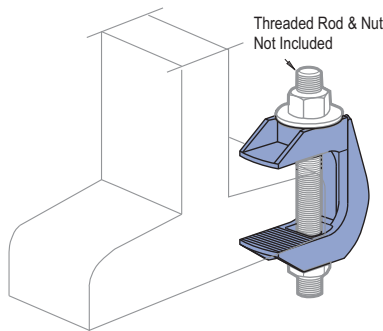

Threaded Rod & Nut Not Included

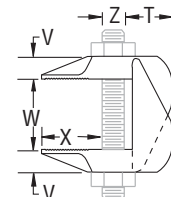
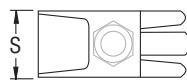

Part Number	Rod Size	Wt/100 pcs Lbs (kg)	Max. Allowable Load Lbs (kN)	Torque Ft-Lbs	Dimensions					
					"X" In (mm)	"W" In (mm)	"V" In (mm)	"T" In (mm)	"S" In (mm)	
PLF9037	3/8"	55 24.9	440 1.96	15	1	3/4 - 1 1/16	1/2	3/4	1	
					25.4	19.1 - 42.9	12.7	19.1	25.4	
PLF9050	1/2"	122 55.3	630 2.80	29	1 1/8	1 - 2 3/8	2 1/32	1 5/16	1 3/16	
					34.9	25.4 - 60.3	16.7	23.8	30.2	
PLF9062	5/8"	200 90.7	1,260 5.60	69	1 1/16	1 1/8 - 2 1/4	1 3/16	1 1/8	1 3/8	
					42.9	28.6 - 69.9	20.6	28.6	34.9	
PLF9075	3/4"	367 166.5	1,880 8.36	131	2	1 1/4 - 3 1/4	1	1 1/8	1 3/4	
					50.8	31.8 - 82.6	25.4	34.9	44.5	
PLF9100	1"	1,101 499.4	3,150 14.01	173	3	1 3/4 - 3 3/4	1 1/2	2 1/8	2 1/2	
					76.2	44.9 - 95.3	38.1	55.6	63.5	

Material: Malleable Iron.

Safety Factor: 4

Note: When used for mechanical supports, load capacities of brackets, fittings and other supporting elements should be in compliance with the American Standard Code for Pressure Piping. Clamps are designed to be used with W, M, S & HP Shape beams, Standard C & Misc. MC Channels, Angles & Structural Tees. Clamps must be used in pairs where indicated. For beam clamps with HG finish, standard hardware is EG finish. For optional stainless steel hardware, please contact the factory for availability.