

CATALOG

UNISTRUT®

UNIPIER® ROOFTOP PIPE SUPPORT SYSTEM

Strut, Conduit & Pipe Support • Pipe Hangers • Custom Fabrication • Support Solutions

A BRAND OF





UNIPIER®

ROOFTOP PIPE SUPPORT SYSTEM

Sleeper Support		Accessories	
Product	4	Spacer	12
Application Examples.....	5	Support Pads, Deck Plates	12
Strut Support		Polycarbonate Roller	12
Product	6	Pipe Hanger Bases	
Application Examples`	7	Polycarbonate and Steel	13
Conduit Supports		Fabricated Supports	
Mounted Support, Polycarbonate Base	8	Single Base Trapeze.....	14
Elevated Support, Polycarbonate Base	8	Double Base Trapeze	15
Elevated Support, Steel Base	8	Heavy Duty Double Base Trapeze.....	15
Gas and Mechanical Supports		Double Base Duct Support	16
Mounted Support, Polycarbonate Base	9	Mechanical Supports	17
Mounted Support, w/Roller Polycarbonate Base	9	Walkway.....	17
Elevated Support, w/Roller, Polycarbonate Base	10	Crossover	18
Elevated Support, w/Roller, Steel Base	11	Installation	19
Elevated Support [Roof Mount], w/Roller, Steel Base	11	Pipe Diameters and Loading	20
		Technical Data	21 – 22

Sleeper Support

Strut Support

Conduit Support

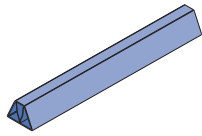

Rooftop Sleeper Support
Pages 4 - 5

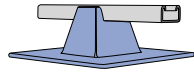

Model UP Strut Support
Page 6

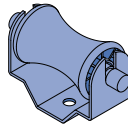

M-RBS Roller for
Model UP Strut Support
Page 6

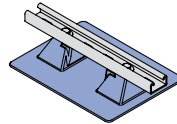

Mounted
Polycarbonate Base
Page 8

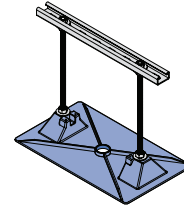

Elevated Support
Polycarbonate Base
Page 8

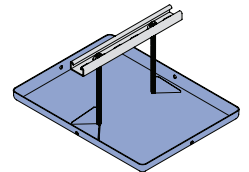

Elevated Support
Steel Base
Page 8

Gas and Mechanical Support

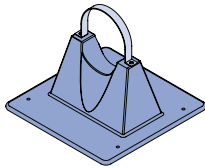

Mounted
Polycarbonate Base
Page 10

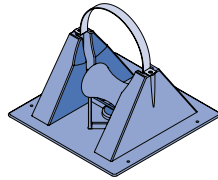

Mounted, w/Roller
Polycarbonate Base
Page 10

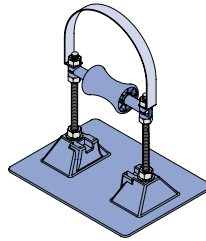

Elevated Support, w/Roller
Polycarbonate Base
Page 10

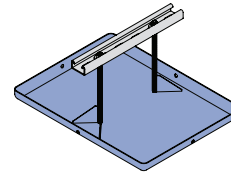

Elevated Support, w/Roller
Steel Base
Page 11

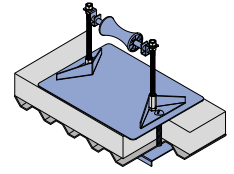

Elevated Support [Roof Mount],
w/Roller, Steel Base
Page 11

Accessories

Pipe Hanger Bases

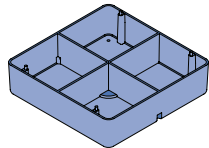

Spacer for Model 1.5, 3-R
Page 14



3" and 5" Roller
Page 15

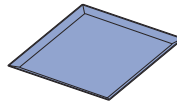

Support Pads &
Deck Plates
Page 14

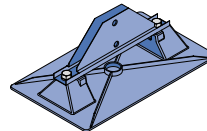

Polycarbonate Bases
Page 15

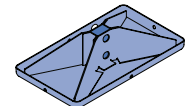

Steel Bases
Page 15

Fabricated Supports

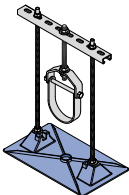

Single Base Trapeze
Page 14

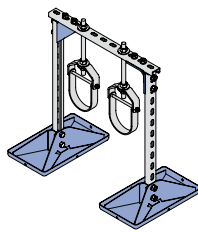

Double Base Trapeze
Page 15

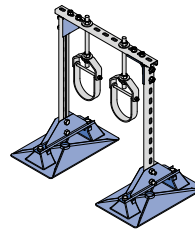

Heavy Duty, Double Base Trapeze
Page 15

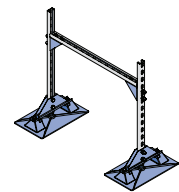

Double Base Duct Support
Page 16

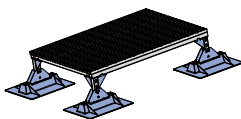

Heavy Duty Mechanical Support
Page 17

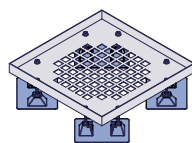

Light Duty Mechanical Support
Page 17

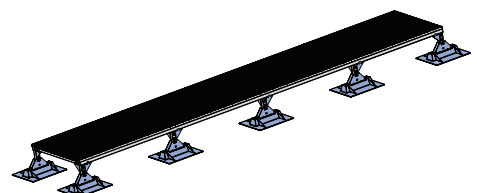

Walkways and Cross Overs
Page 17-18

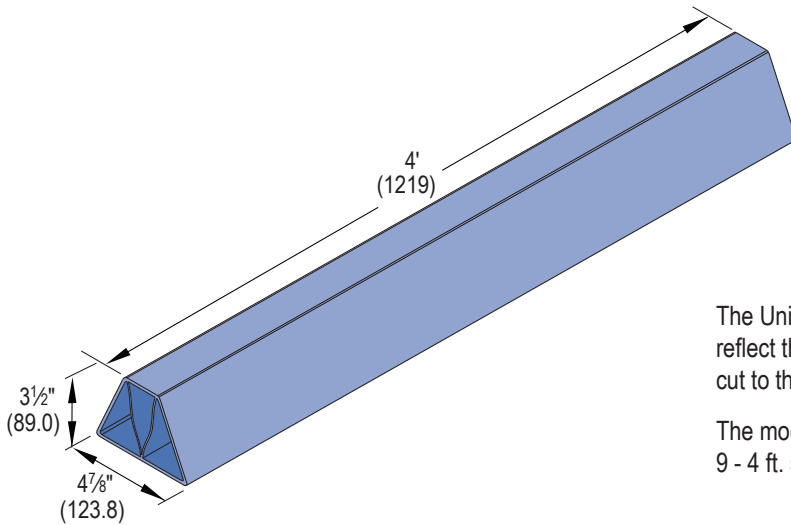

The Unipier rooftop sleeper is the first rooftop support that is white to reflect the sun's UV rays. It is cost-effective, lightweight and can be cut to the desired length while on the job site.

The model RSS4 is conveniently packaged in shrink wrap bundles of 9 - 4 ft. supports that can be easily carried to the rooftop.



The Unipier sleeper support is lightweight, just 4 lbs./4 ft. section, so it is easily transported to the job site in bundles of 9 supports.



The Unipier sleeper support can be conveniently cut to lengths of 6" or longer right on the job site.



TEK screws or other self tapping fasteners are used to attach conduit supports, pipe clamps or other clamping fittings.

NOTE: Load not to exceed 50 lbs./6" length

Part Number: RSS4

The Sleeper Support is not restricted to just pipe clamps. It makes a perfect companion for the Unistrut Roofwalk panels.

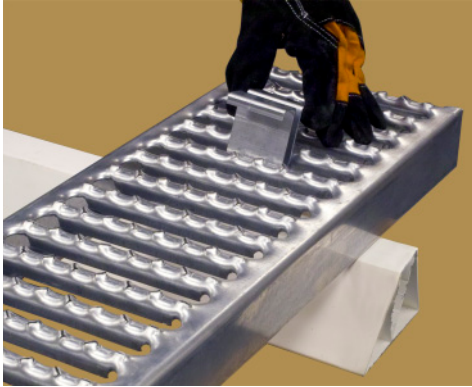

Position the grating on the Unipier sleeper support and insert the appropriate size hold down clip (G639, G607, or G620).

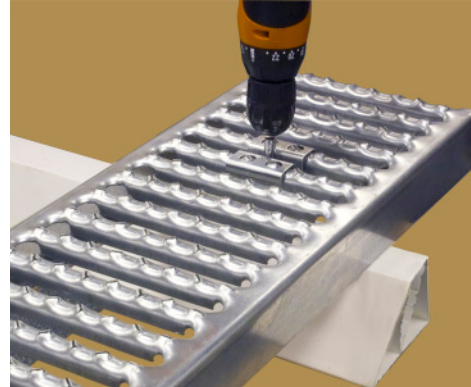

Use a TEK screw to attach the hold down clip.

That's all that is required!

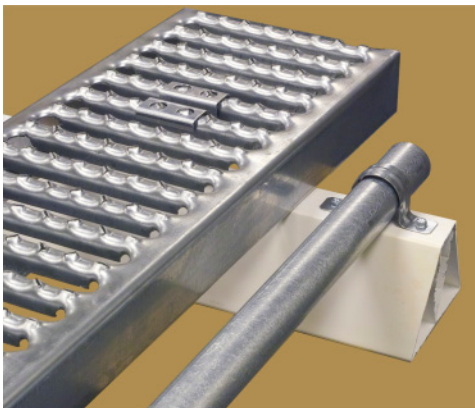

You can even use the Unipier support for multiple tasks. Here we have a grating walk and a piece of electrical conduit attached to the sleeper.

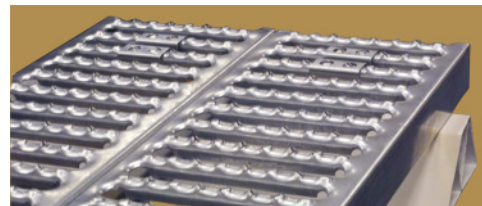

Grating can also be used to construct a platform for heavy equipment or even as a workstand.



UP-SPSS Style Support

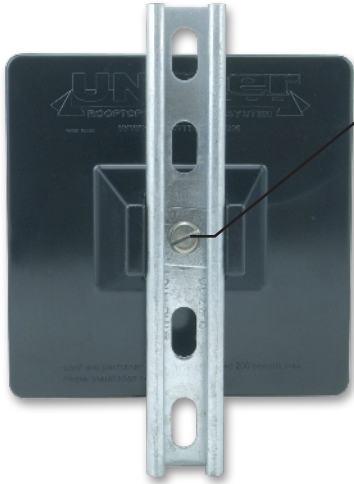

- Align Center hole of P4100T on base.
- Place square washer inside P4100T.
- Insert screw & torque to 19 ft./lbs.

Part Number	Qty. Unipier Bases	Supporting Channel	
		Qty.	Description
UP-BK	4	0	Base Only
UP-SPSS-6 HG	4	4	6" - P4100T HG (up to 3½" Pipe)
UP-SPSS-10HG	4	4	10" - P4100T HG (4" to 8" Pipe)

NOTE:

1. The maximum uniform load on P1000T is 400 lbs.
2. Uniform load is limited by roof base allowed load of 200 lbs. (5 psi on roof).

Single Pier Installation

1. Align center hole of Unistrut P4100T on base and attach using supplied hardware. Torque screw to 19 ft./lbs.
2. Place pipe/tubing on P4100T and attach pipe/tubing clamp.

UP-MPDS Style Support

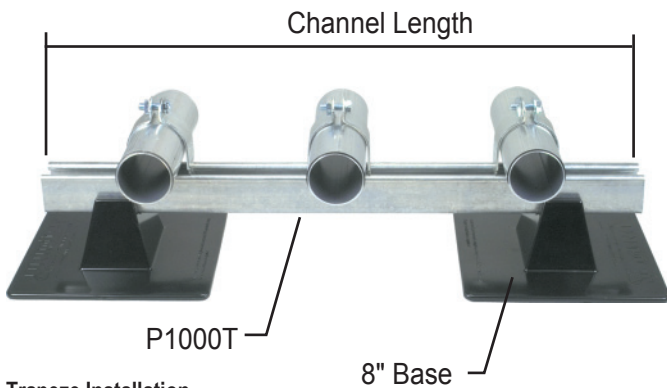

Trapeze Installation

1. Align end holes of Unistrut P1000T on bases and attach using supplied hardware. Torque screw to 19 ft./lbs.
2. Place pipe/tubing on support and attach with appropriate pipe/tubing clamp.

Part Number	Qty. Unipier Bases	Supporting Channel	
		Qty.	Description
UP-MPDS-26HG	4	2	26" - P1000T HG for Trapeze
UP-MPDS-38HG	4	2	38" - P1000T HG for Trapeze
UP-MPDS-50HG	4	2	50" - P1000T HG for Trapeze
UP-MPDS-62HG	4	2	62" - P1000T HG for Trapeze

NOTE:

1. The maximum uniform load on P1000T is 400 lbs.
2. Uniform load is limited by roof base allowed load of 200 lbs. (5 psi on roof).

NOTE: Kits do not include pipe/tubing or clamps.

M-RBS

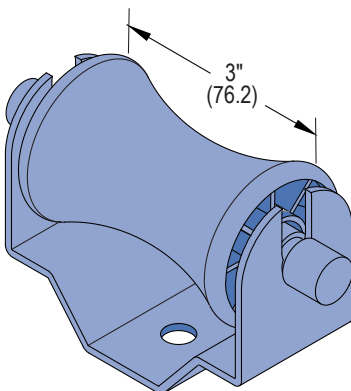

The M-RBS roller is designed for use with the UP-BK base. The roller is made of polycarbonate and the roller rod is 6/6 nylon.

Note: Maximum load is 100 lbs. and should not extend more than 12" above the roof.
Wt./Ea.: 0.7 lbs.

Support Spacing

Pipe Size (Nom.)	Support Spacing			
	Sch. 40 Pipe Water-Filled ^(a)		Conduit GRC ^(b)	
	Single Pier	Trapeze ^(d)	Single Pier	Trapeze ^(d)
3/8"	7'	7'	N/A	N/A
1/2"	7'	7'	10'	10'
3/4"	7'	7'	10'	10'
1"	7'	7'	12'	12'
1 1/4"	7'	7'	14'	14'
1 1/2"	9'	9'	14'	14'
2"	10'	10'	16'	16'

Pipe Size (Nom.)	Support Spacing			
	Sch. 40 Pipe Water-Filled ^(a)		Conduit GRC ^(b)	
	Single Pier	Trapeze ^(d)	Single Pier	Trapeze ^(d)
2 1/2"	11'	11'	16'	16'
3"	12'	12'	13 ^(c)	20'
3 1/2"	13'	13'	11 ^(c)	20'
4"	12 ^(c)	14'	9 ^(c)	20'
5"	8 ^(c)	16'	6 ^(c)	20'
6"	6 ^(c)	17'	4 ^(c)	20'
8"	4 ^(c)	19'	N/A	N/A

Note:

- (a) Based on ANSI/MSS SP-69, 2003 Edition, Table 3.
- (b) Based on 2002 NEC, Table 344.30(B)(2).
- (c) Spacing limited to roof base allowed load of 200 lbs. (5 psi on roof).
- (d) Spacing may be limited by maximum allowed weight on trapeze to 400 lbs.

Application Examples

Unipier Rooftop Support System provides a simple and versatile way to support and manage pipe, tubing, conduit, HVAC systems, and the like. The Unipier Rooftop Support System does not require roof surface penetration and allows the parts to remain off the surface.

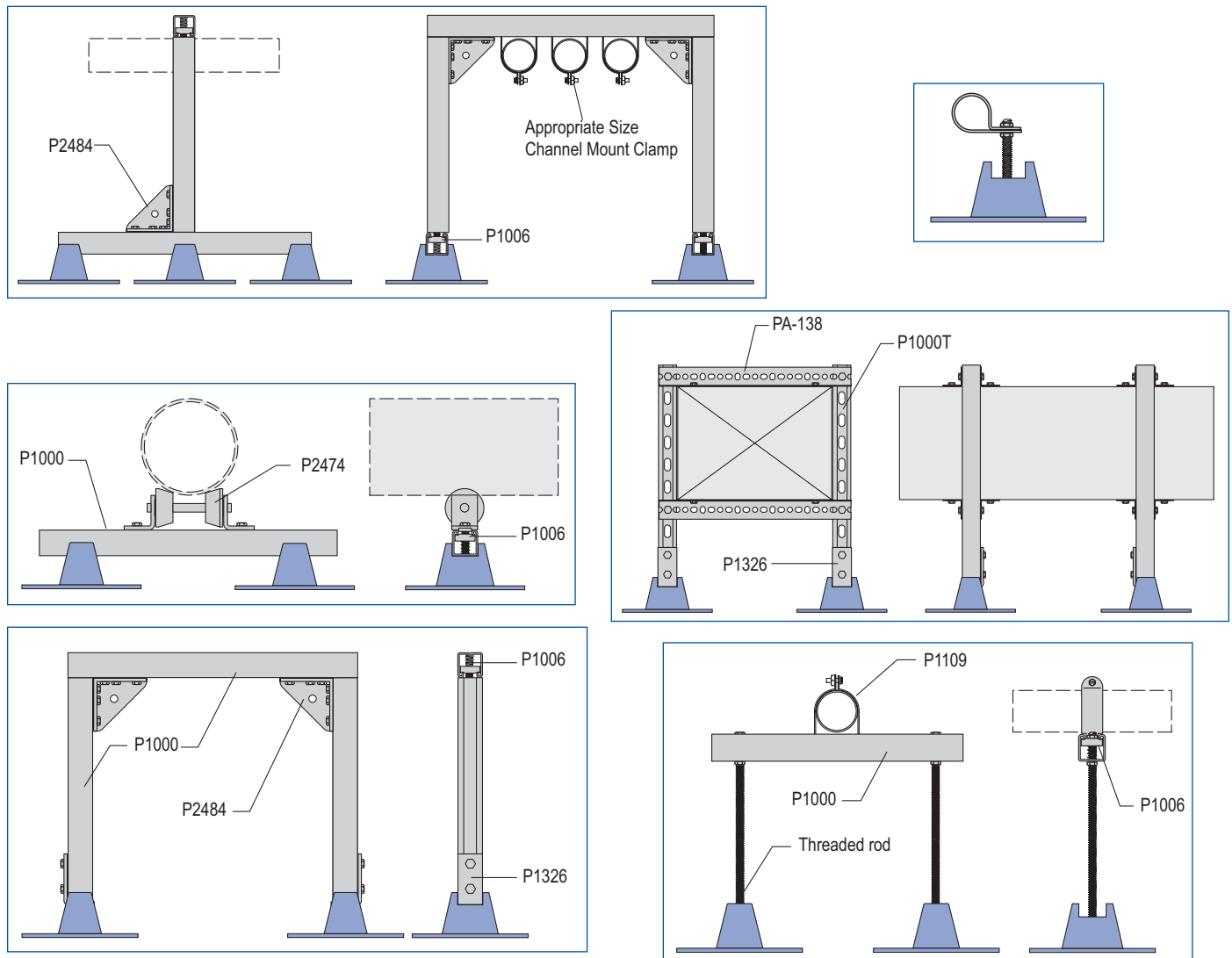



Mounted Support, Polycarbonate Base

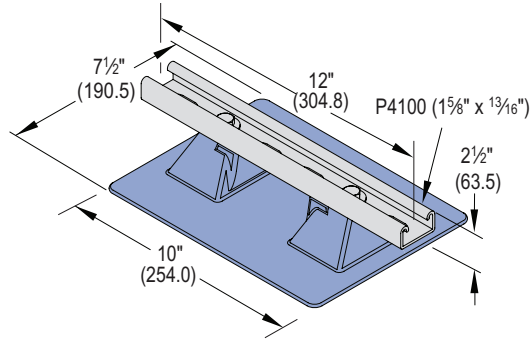

Part Number	Material	Max. Uniform Load	Wt./Each
2.5-CS-2	Polycarbonate	100 lbs.	2.3 lbs.

Determining Maximum Pipe Size

Maximum pipe size supported by any of the strut supports is determined by the load and the clear space required between the pipes. The spacing between pipes should be as follows:

- 1" between piping 3" and smaller.
- 1-1/2" between a pipe 3" and smaller and a pipe 4" or larger.
- 2" between piping 4" and larger.
- At least 1" between pipe clamp and end of strut

For example, a support for two 3" pipes would require:
 $1" + 3" + 1\text{-}1/2" + 3" + 1" = 9\text{-}1/2"$ wide channel support

Elevated Support, Polycarbonate Base

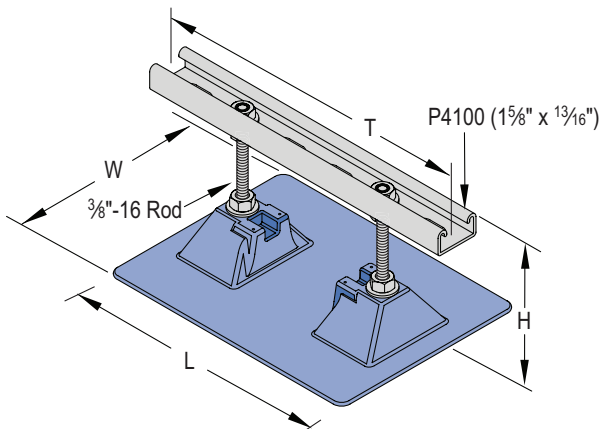

Note: Base for 2.5-CS-5, 2.5-CS-7 shown. Other bases have additional support or flanges to handle the increased loads.
 All bases are polycarbonate material

Part Number	"H" (max) in. (mm)	"W" in. (mm)	"L" in. (mm)	"T" in. (mm)	Max. Uniform Load	Wt./Each (lbs.)
2.5-CS-5	5" (127.0)	7 1/2" (190.5)	10" (254.0)	12" (304.8)	100 lbs.	2.1
2.5-CS-7	7 1/2" (190.5)	7 1/2" (190.5)	10" (254.0)	12" (304.8)	100 lbs.	2.5
2.5-CS-12	12" (304.8)	9" (228.6)	15 1/4" (387.4)	12" (304.8)	100 lbs.	4.0
16-BS-7	7" (190.5)	9" (228.6)	15 1/4" (387.4)	16" (406.4)	125 lbs.	5.0
16-BS-12	12" (304.8)	9" (228.6)	15 1/4" (387.4)	16" (406.4)	125 lbs.	7.5
20-BS-7	7" (190.5)	16" (406.4)	18" (457.2)	20" (508.0)	250 lbs.	9.8
20-BS-12	12" (304.8)	16" (406.4)	18" (457.2)	20" (508.0)	150 lbs.	14.5

Elevated Support, Steel Base

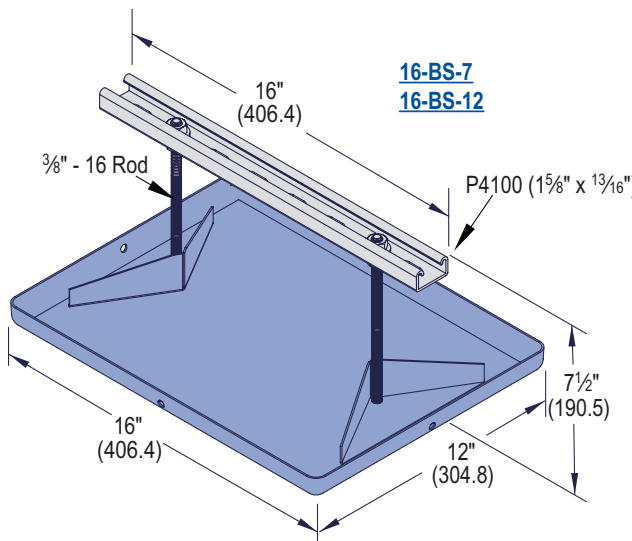

16-BS-7
16-BS-12

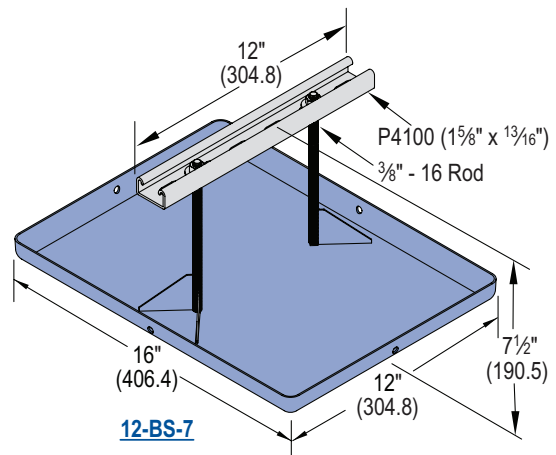

12-BS-7

Part Number	Material	Max. Uniform Load	Wt./Each
16-BS-7 HDG	Hot-Dipped Galvanized	150 lbs.	7.5 lbs.
16-BS-7 SS	Stainless Steel	150 lbs.	7.5 lbs.

Part Number	Material	Max. Uniform Load	Wt./Each
12-BS-7 HDG	Hot-Dipped Galvanized	150 lbs.	7.5 lbs.
12-BS-7 SS	Stainless Steel	150 lbs.	7.5 lbs.

Mounted, Polycarbonate Base

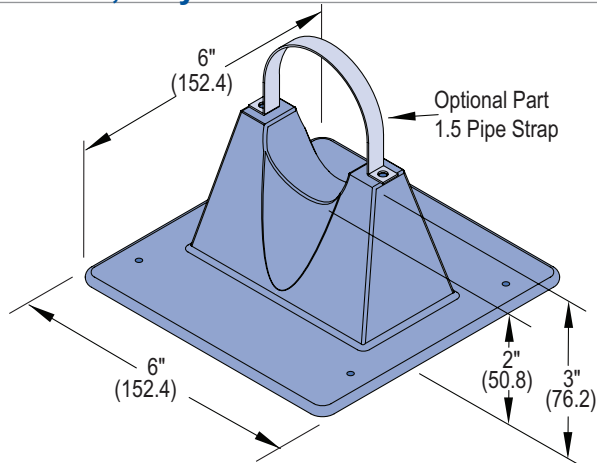

Part Number	Max. Pipe Capacity	Max. Uniform Load	Wt./Ea.	Optional Pipe Strap
1.5 Pipe Support	1½" ID , 1.9" OD	80 lbs.	0.35 lbs.	1.5 Pipe Strap

Note: Base is polycarbonate

Optional pipe strap aluminum w/SS Screws

Mounted, with Roller, Polycarbonate Base

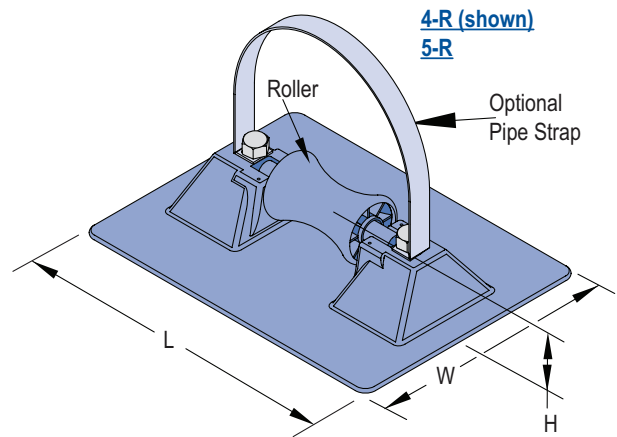
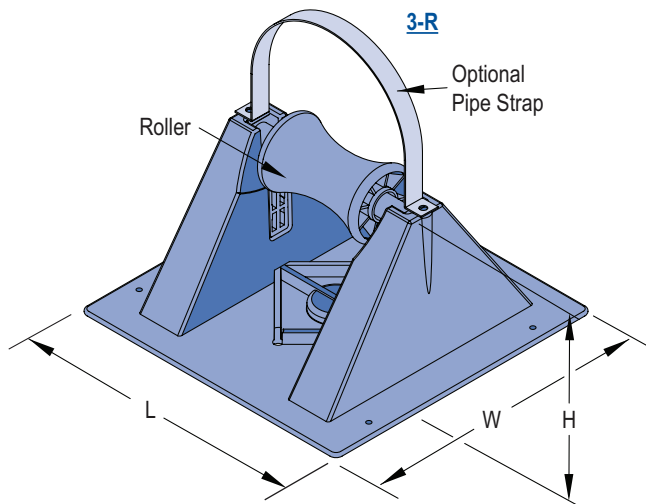

Note: All bases are polycarbonate

Optional pipe strap aluminum w/SS Screws

Part Number	"H" in. (mm)	"W" in. (mm)	"L" in. (mm)	Roller size	Max. Pipe Capacity	Max. Uniform Load	Wt./Ea. Lbs.	Optional Pipe Strap
3-R-2	2.15" (54.6)	7 ¾" (196.9)	7 ¾" (196.9)	3" (76.2)	3" ID 3 ¾" OD	100 lbs.	1.1 lbs.	3-R-2 Pipe Strap
3-R-4	4" (101.6)	7 ¾" (196.9)	7 ¾" (196.9)	3" (76.2)	3" ID 3 ¾" OD	100 lbs.	1.2 lbs.	3-R-4 Pipe Strap
4-R	2.15" (54.6)	7 ½" (190.5)	10" (254.0)	3" (76.2)	4" ID 5" OD	135 lbs.	1.0 lbs.	4-RAH Pipe Strap
5-R	2.35" (59.7)	9" (228.6)	15 ¼" (387.4)	5" (127)	5" ID 6" OD	150 lbs.	2.4 lbs.	6-RAH Pipe Strap



Elevated Support, with Roller, Polycarbonate Base

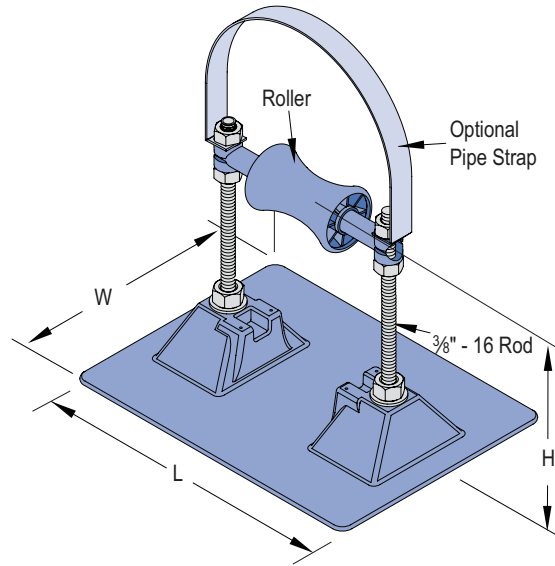

Note: Base for 3-RAH-7, 4-RAH-7 shown. Other bases have additional support or flanges to handle the increased loads.

All bases are polycarbonate material

Optional pipe strap aluminum w/SS Screws

Part Number	"H" (max) in. (mm)	"W" in. (mm)	"L" in. (mm)	Roller Size in. (mm)	Max. Pipe Capacity	Max. Uniform Load	Wt./Ea. Lbs.	Optional Pipe Strap
3-RAH-7	7" (177.8)	7 1/2" (190.5)	10" (254.0)	3" (76.2)	3" ID 3 3/4" OD	100 lbs.	1.9	4-RAH Pipe Strap
3-RAH-12	12" (304.8)	9" (228.6)	15 1/4" (387.4)	3" (76.2)	3" ID 3 3/4" OD	100 lbs.	5.8	4-RAH Pipe Strap
4-RAH-7	7" (177.8)	7 1/2" (190.5)	10" (254.0)	5" (127)	4" ID 5" OD	125 lbs.	1.9	4-RAH Pipe Strap
4-RAH-12	12" (304.8)	9" (228.6)	15 1/4" (387.4)	5" (127)	4" ID 5" OD	125 lbs.	5.8	4-RAH Pipe Strap
5-RAH-7	7" (177.8)	9" (228.6)	15 1/4" (387.4)	5" (127)	5" ID 6" OD	150 lbs.	4.8	6-RAH Pipe Strap
5-RAH-12	12" (304.8)	9" (228.6)	15 1/4" (387.4)	5" (127)	5" ID 6" OD	150 lbs.	4.8	6-RAH Pipe Strap
6-RAH-7	7 1/2" (190.5)	16" (406.4)	18" (457.2)	5" (127)	6" ID 8 1/2" OD	250 lbs.	8.8	6-RAH Pipe Strap
6-RAH-12	12" (304.8)	16" (406.4)	18" (457.2)	5" (127)	6" ID, 8 1/2" OD	250 lbs.	9.8	6-RAH Pipe Strap

Elevated Support, with Roller, Steel Base

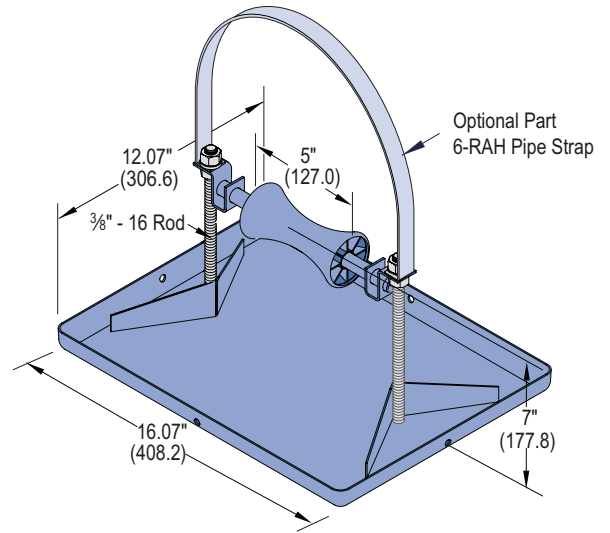
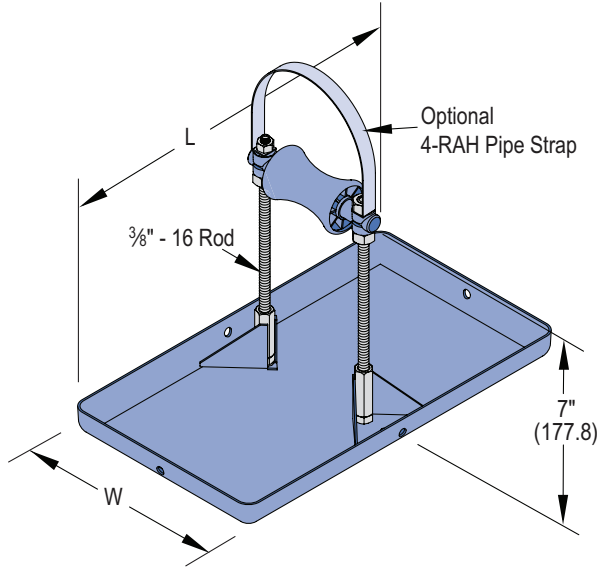

Part Number	"W" in. (mm)	"L" in. (mm)	Roller in. (mm)	Material	Max. Pipe Capacity	Max. Uniform Load	Wt. Each Lbs
3-RAH-7 HDG	8" (203.2)	14" (255.6)	3" (76.2)	Hot-Dipped Galvanized	3" ID 3¾" OD	100 lbs.	3.3
3-RAH-7 SS	8" (203.2)	14" (255.6)	3" (76.2)	Stainless Steel	3" ID 3¾" OD	100 lbs.	3.3
4-RAH-7 HDG	12.07" (306.6)	16.07" (408.2)	5" (127)	Hot-Dipped Galvanized	4" ID 5" OD	150 lbs.	6.8
4-RAH-7 SS	12.07" (306.6)	16.07" (408.2)	5" (127)	Stainless Steel	4" ID 5" OD	150 lbs.	5.8

Part Number	Material	Max. Uniform Load	Max. Pipe Size	Wt. Ea. Lbs.
6-RAH-7 HDG	Hot-Dipped Galvanized	150 lbs.	6" ID 8½" OD	8.8
6-RAH-7 SS	Stainless Steel	150 lbs.	6" ID 8½" OD	8.8

Note: Optional 6-RAH Pipe Strap aluminum w/SS Screws

Note: Optional 4-RAH Pipe Strap aluminum w/SS Screws

Elevated Support [Roof Mount], with Roller, Steel Base and Steel Backer

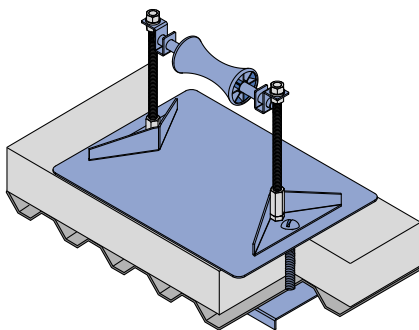

Installation Example

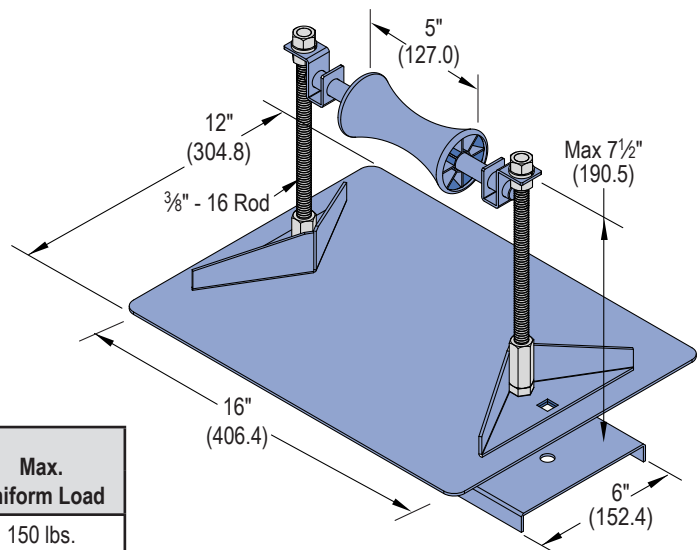

Part Number	Material	Max. Pipe Size		Max. Uniform Load
		ID	OD	
6-RAH-RS HDG	Hot-Dipped Galvanized	6"	1 ½"	150 lbs.
6-RAH-RS SS	Stainless Steel	6"	1 ½"	150 lbs.



Spacer for Model 1.5 and Model 3-R

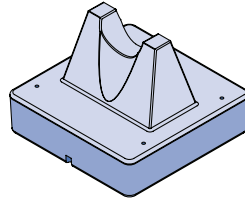

Example: Spacer with Model 1.5

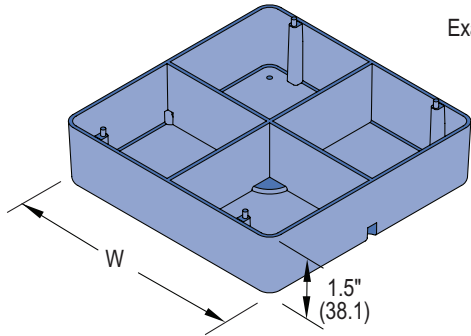

Part Number	Use With	"W"	Added Pipe Clearance	Wt./Ea.
1.5 Spacer	1.5	6"	1 1/2"	0.43 lbs
3-R Spacer	3-R-2 or 3-R-4	7-1/2"	2"	0.75 lbs

Material: Polycarbonate

Support Pad, Polycarbonate

Deck Plate, Steel

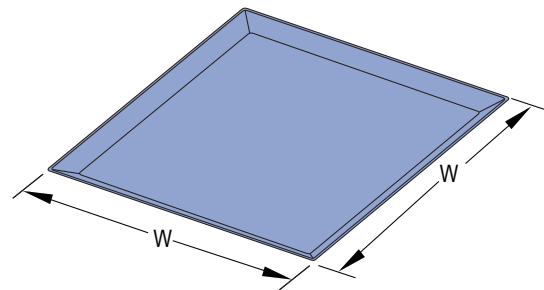
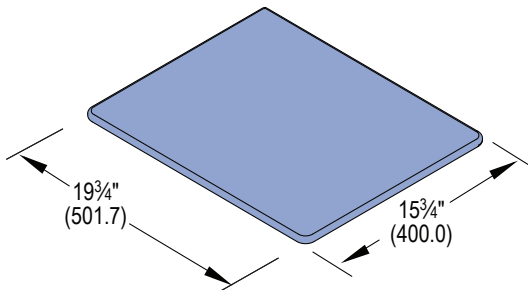

Part Number	Material	Max. Pipe Capacity	Wt./Each
Deck Plates 12 SS	Stainless Steel	12"	2.0 lbs.
Deck Plates 18 SS	Stainless Steel	18"	4.5 lbs.

Note: Contact Unistrut for larger sizes.

Polycarbonate Roller

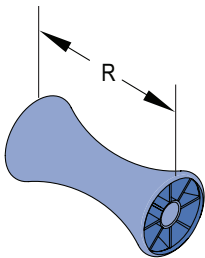

Part Number	"R"	Shaft	End Diameter
Roller 3	3"	5/8"	1 7/8"
Roller 5	5"	5/8"	2 7/8"

Polycarbonate Base

Model 6-H Base P

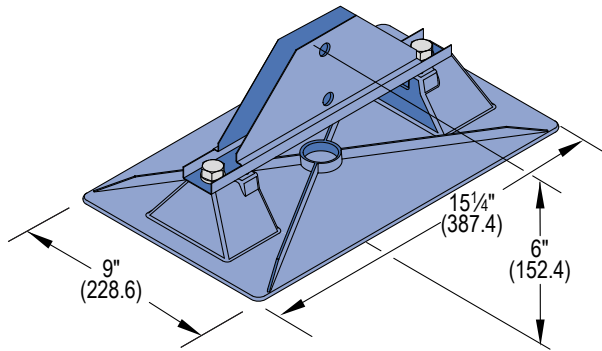

Note: Maximum 150 lbs. Load
Wt./Ea.: 2.5 lbs.

Model 8-H-SB Base P

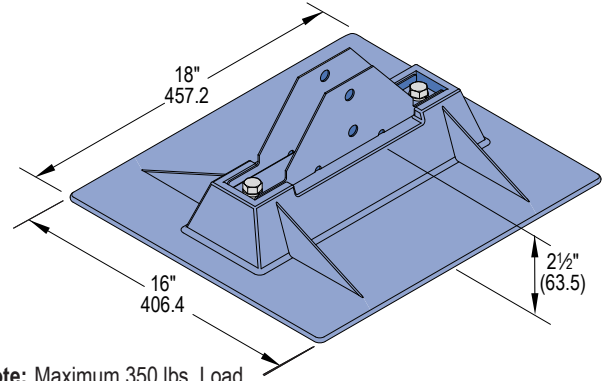

Note: Maximum 350 lbs. Load
Wt./Ea.: 5.5 lbs.
Note: Contact Unistrut for optional configuration to allow for adjustability.

Model 8-H-DB Base P

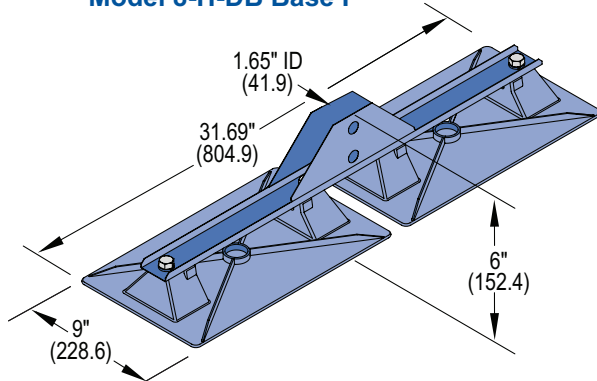

Note: Maximum 350 lbs. Load
Wt./Ea.: 4.5 lbs.

Model 16-H Base P

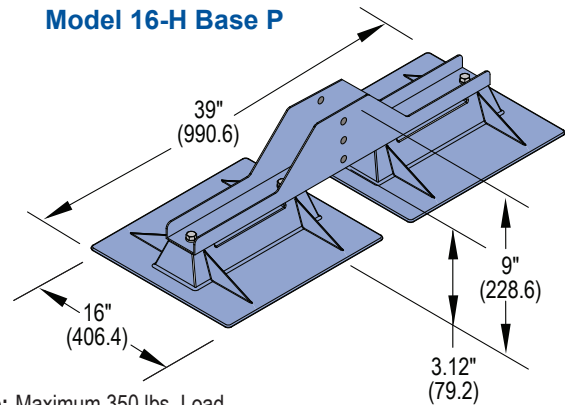

Note: Maximum 350 lbs. Load
Wt./Ea.: 18.5 lbs.

Steel Base

Model 5-H Base HDG

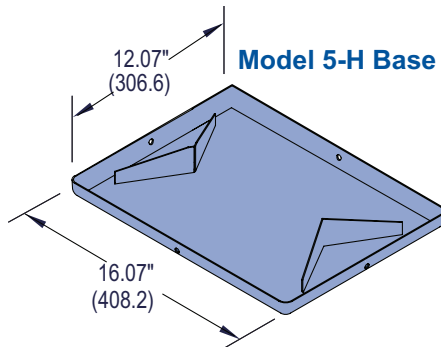

Model 6-H, 8-H, 16-H Base HDG

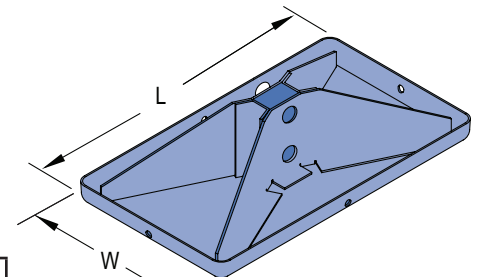

Part Number	"W"	"L"
6-H Base HDG	8" (203.2mm)	14" (355.6mm)
6-H Base SS	8" (203.2mm)	14" (355.6mm)
8-H Base HDG	16" (406.4mm)	12" (304.8mm)
8-H Base SS	16" (406.4mm)	12" (304.8mm)
16-H Base HDG	20" (508mm)	20" (508mm)
16-H Base SS	20" (508mm)	20" (508mm)



Custom Fabrication

The Unipier products offer a great deal of flexibility. If you do not find an “off-the-shelf” support for your particular application, contact Unistrut with your requirements. We can design and build the proper support for your unique application.

Samples of typical custom fabrications are shown in this section of the catalog.

Custom products are shown on the following pages. For a quotation on custom fabrication, contact Unistrut with the parameters for your design as shown below.

Pipe Stands

1. Quantity of supports required (or total footage of pipe)
2. Type of pipe
3. Size of pipe and number of pipes per support
4. Pipe contents
5. Clearance height above roof
6. Thickness of any insulation around pipe

Duct and Cable Tray Supports

1. Dimension of duct
2. Clearance height above roof
3. Total footage of duct
4. Thickness of insulation, if any

Crossover, Walkway, Ramp and Platforms

1. Width and length desired
2. Height off roof
3. Specify if railing is needed
4. Type of roof

Mechanical Supports

1. Width and length desired
2. Height off roof
3. Weight of unit

Single Base Trapeze

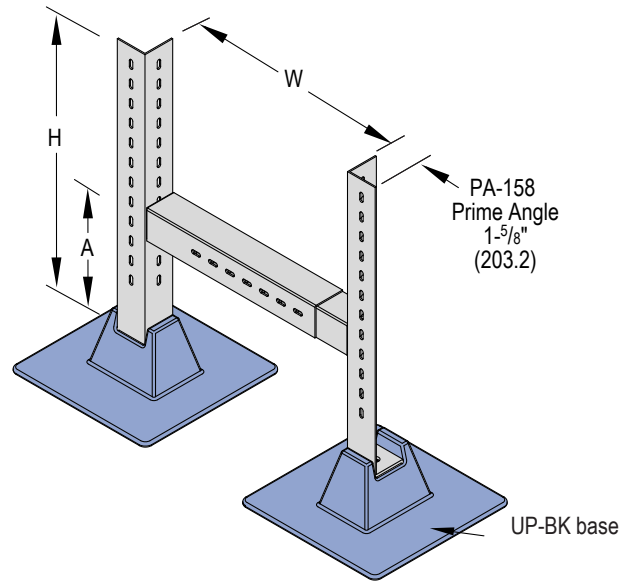
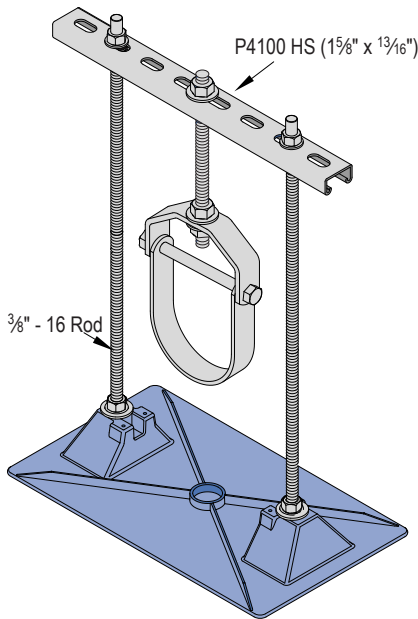

Part Number	Material	Max. Uniform Load Per Pipe Stand
2.5-SB-H (shown above)	Polycarbonate	125 lbs.
5-SB-H	Polycarbonate	250 lbs.
5-SB-H HDG	Hot-Dipped Galvanized	170 lbs.

NOTE: For maximum pipe size, refer to note on page 8.

Base Number	H	W	A	Max. Uniform Load Per Duct
UP-BK	17" (431.8)	8" to 12" (203.2 to 304.8)	6" to 12" (152.4 to 304.8)	25 lbs.
UP-BK	24" (609.6)	12" to 18" (304.8 to 457.2)	6" to 18" (152.4 to 457.2)	50 lbs.

Base Material: Polycarbonate

Double Base Trapeze

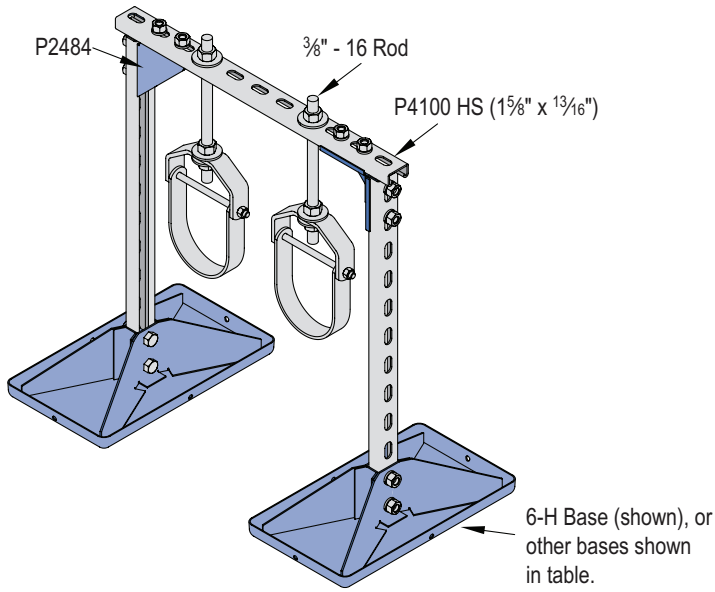

Part Number	Material	Max. Uniform Load		Max. Pipe Capacity
		Per Pipe Stand	Per Base	
6-H Base P	Polycarbonate	300 lbs.	150 lbs.	6" ID 7 1/2" OD
8-H-SB Base P	Polycarbonate	700 lbs.	350 lbs.	8" ID 9" OD
6-H Base HDG	Hot-Dipped Galvanized	300 lbs.	150 lbs.	6" ID 7 1/2" OD
6-H Base SS	Stainless Steel	300 lbs.	150 lbs.	6" ID 7 1/2" OD
8-H Base HDG	Hot-Dipped Galvanized	700 lbs.	350 lbs.	8" ID 9" OD
8-H Base SS	Stainless Steel	700 lbs.	350 lbs.	8" ID 9" OD
16-H Base HDG	Hot-Dipped Galvanized	1,600 lbs.	800 lbs.	16" ID 18" OD
16-H Base SS	Stainless Steel	1,600 lbs.	800 lbs.	16" ID 18" OD

Heavy Duty Double Base Trapeze

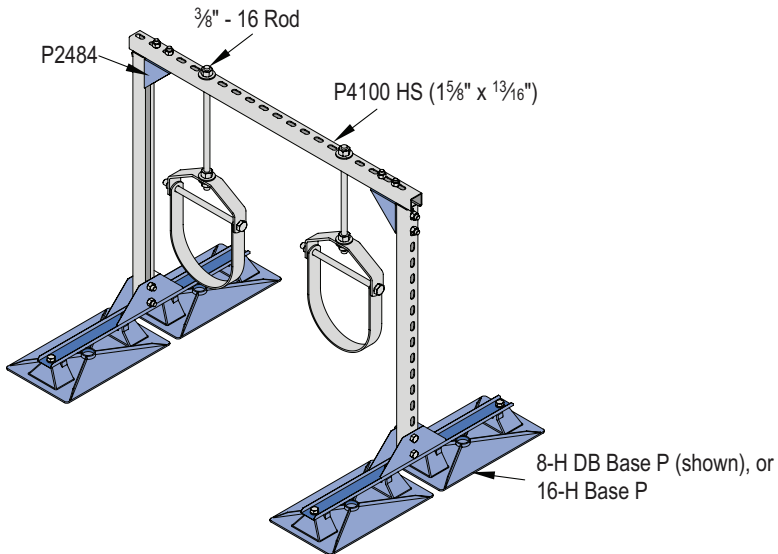

Part Number	Max. Uniform Load		Max. Pipe Capacity
	Per Pipe Stand	Per Base	
8-H-DB Base P	700 lbs.	350 lbs.	8" ID 9" OD
16-H Base P	1,600	800	16" ID 18" OD

Base Material: Polycarbonate



Double Base Duct Support

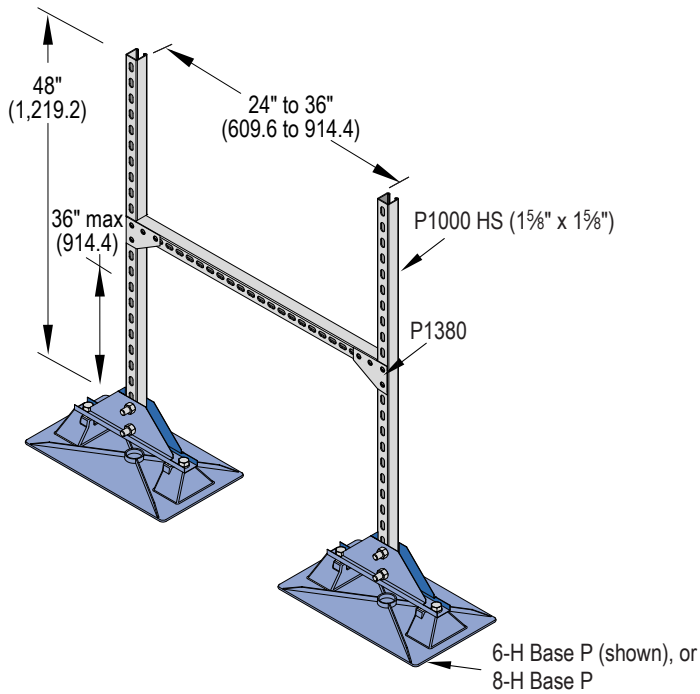

Base Number	Material	Max. Uniform Load Per Duct
6-H Base P	Polycarbonate	150 lbs.
8-H Base P	Polycarbonate	300 lbs.

Double Base Duct Support

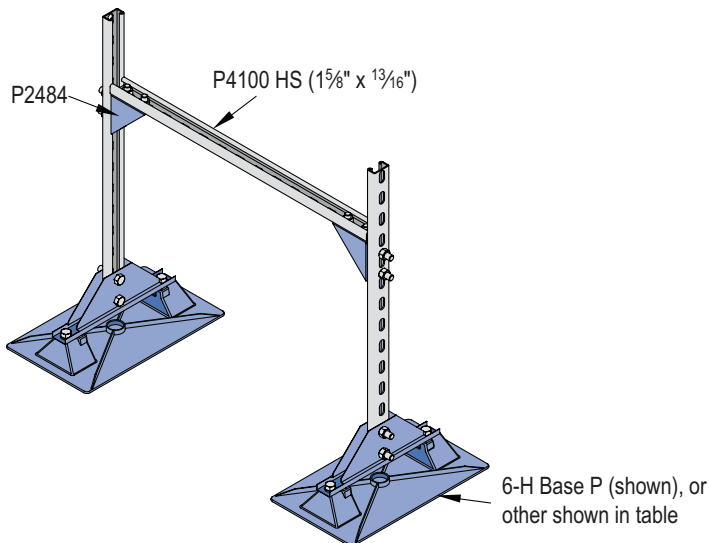

Base	Material	Max. Uniform Load	
		Per Duct	Per Base
6-H Base P	Polycarbonate	150 lbs.	75 lbs.
6-H Base HDG	Hot-Dipped Galvanized	300 lbs.	150 lbs.
6-H Base SS	Stainless Steel	300 lbs.	150 lbs.
8-H-SB Base P	Polycarbonate	300 lbs.	150 lbs.
8-H Base HDG	Hot-Dipped Galvanized	300 lbs.	150 lbs.
8-H-DB Base SS	Stainless Steel	300 lbs.	150 lbs.
8-H-DB Base P	Polycarbonate	300 lbs.	150 lbs.

Heavy Duty Mechanical Support

Light Duty Mechanical Support

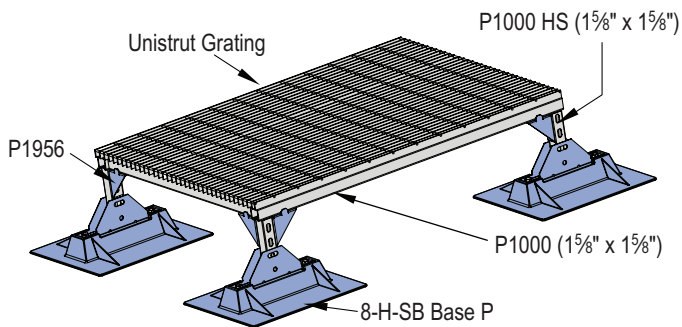

Note: Adjustable height, maximum load 600 lbs.
Note: Contact Unistrut for size information.

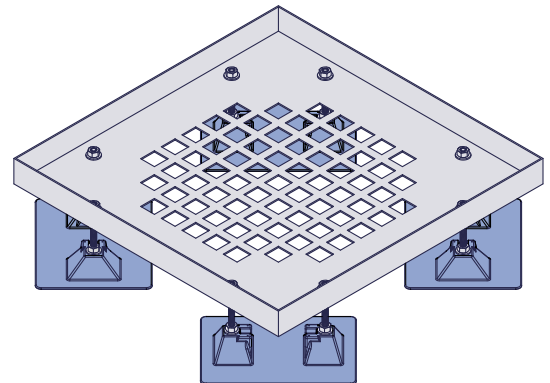

Note: Adjustable height, maximum load 200 lbs.
Available Sizes: 18" x 18", 24" x 24", 30" x 30", 36" x 36"
Note: Custom sizes available, Contact Unistrut for information.

Walkway

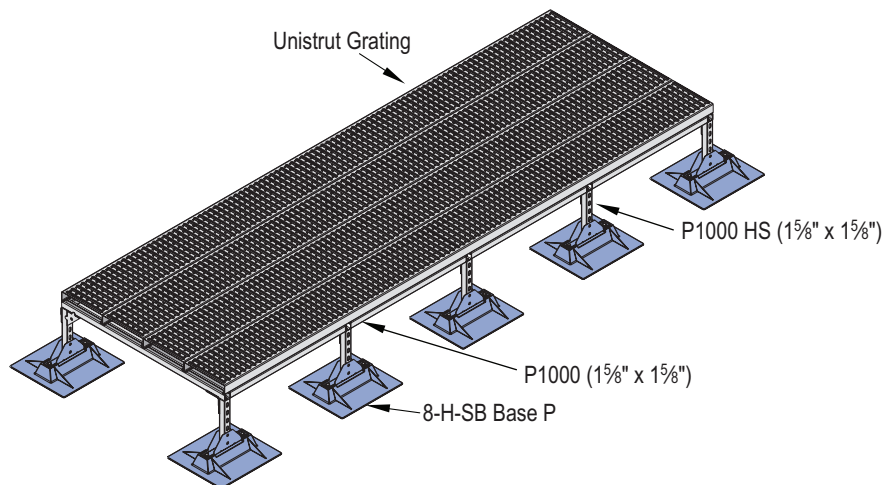



Cross Over

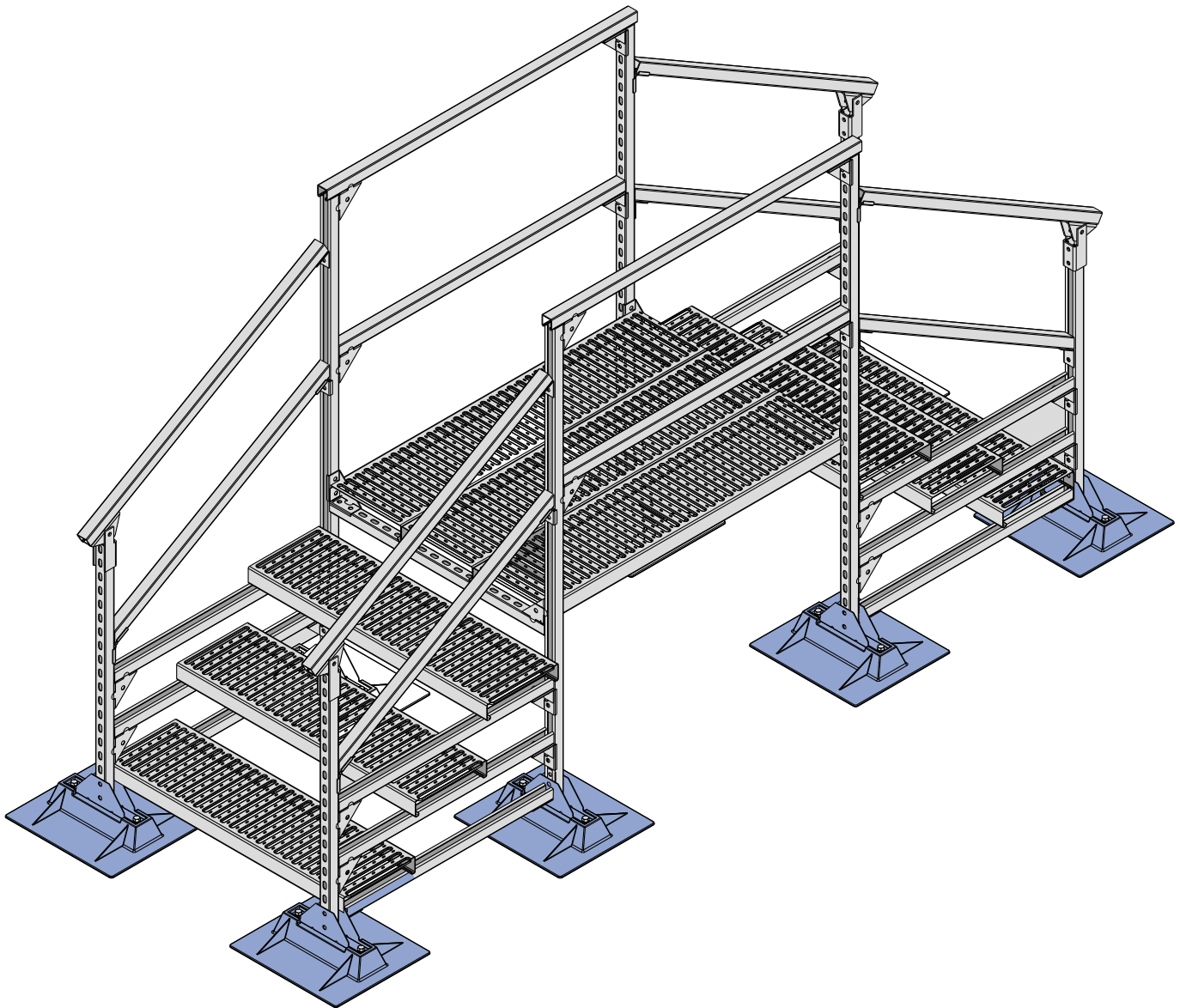

Product Description:

A pipe support used to support roof mounted gas pipes, electrical conduit, solar piping and other mechanical piping. Unique design absorbs thermal expansion and contraction of pipes thus preventing damage to the roof membrane. Pipes rests include:

- "U" shaped cradle situated in a polycarbonate resin seat.
- Self-lubricating roller polycarbonate resin rod and roller. As daytime temperatures warm the roof membrane and the mechanical pipe network found on the roof, causing them to expand, the roller bearing in the pipe stand rolls beneath the pipe it supports. A difference between night and day temperatures of 20° F. causes 100 ft. of 1" steel pipe to move as much as 1/4".
- A strut system constructed of hot-dipped galvanized steel components including clevis hangers or band hangers.
- For the duct supports, the ducts rest on a 1 5/8" x 1 5/8" or 1 5/8" x 7/8" Unistrut channel and are adjustable in height.

Composition and Material:

Support base is made of polycarbonate resin or hot-dipped galvanized or stainless steel as indicated for the specific base. The base is gently rounded to prevent gouging the roof membrane. Carbon black is added to the polycarbonate resin for UV resistance and protection.

Pipe Roller is made of polycarbonate, or steel as indicated for the specific part.

Other Metal Parts are made of hot-dipped galvanized or stainless steel.

Duct Supports are made of hot-dipped galvanized Unistrut channel

All-Thread Rod are 1/2" or 3/8" stainless steel and are used for vertical supports.

Compatibility:

Pillow Block Pipe Stands are recommended for use on and compatible with all current types of decking and with all commonly used built-up and single-ply roofing membranes where roof-mounted pipes occur. For heavier loads it is prudent to use a Unipier Support Pad or other traffic pad to further protect the roof membrane.

Adjustable Height:

Several models allow adjustable height as desired or required by the code or roof system. Each model can be configured to allow plus or minus height above the roof. Purchasers should specify desired heights upon ordering the pillow block hangers.

Installation Process:

1. Center the support beneath the pipes or ducts so that the pipe or ducts are squarely over the pipe stand.
2. For adjustable models, adjust the support to the desired height and to ensure a uniform load with other supports. Make certain the horizontal support strut is level.
3. Place the pipe or duct on the support without dropping or causing undue impact.

For heavier loads it is prudent to install an additional sheet of roofing material, a Unipier Deck Plate, or Unipier Support Pad beneath the duct support.

For built-up roofs, all loose aggregate from an area 2" larger than each base should be removed from the area directly beneath the support. Care should be taken to install each support so it supports a proportional and equal amount of weight at each support.

Optional Method of Installation (Not Recommended):

Where code requires or as desired, the supports may be attached to the roof structure by appropriate and compatible rooftop fasteners through holes drilled in the base at the time of installation. For those models using a pitchpan, the pitchpan may be filled with asphalt material or concrete to help seal the areas around the fasteners.

Optional Straps:

For many of the models, the pipe may be secured to the pipe stand by using optional Unipier Pipe Straps.

Note:

When using a pipe strap, allow sufficient room between the pipe and the strap to allow free movement of the pipe without binding.

Loads and Spacing:

Unistrut recommends that spacing not exceed 10' between centers depending upon the load. Make certain each pipe stand is properly elevated to ensure a uniform load weight at all pipe stands and not exceed the load specified for the particular model support. All loads given in this catalog are for uniformly distributed loads.

Maintenance:

Normally maintenance is not required. Semi-annual inspection is required to check pipe stand position and set pipe alignment, weight distribution and improper installation which may cause pipe stand damage or failure.



Typical Steel Pipe Weights – Pipe Standing Load

For Schedule 40 Steel Pipe. (ASTM A53-86)

Pipe Size	Pounds per Foot of Pipe Empty	Pounds per Foot Containing Gas		PSI per Foot on Model 6-RAH-7 BASE	5 Feet Spacing	7.5 Feet Spacing	10 Feet Spacing
		Pounds per Foot Containing Water	Pounds per Foot Containing Gas				
3"	7.575	7.578	.02	37.89 lbs. .13 psi	56.84 lbs. .20 psi	75.78 lbs. .26 psi	
		13.4	.04	67.00 lbs. .23 psi	100.50 lbs. .35 psi	134.00 lbs. .47 psi	
4"	10.790	10.794	.03	53.97 lbs. .19 psi	80.96 lbs. .28 psi	107.94 lbs. .37 psi	
		16.3	.05	81.50 lbs. .28 psi	122.25 lbs. .42 psi	163.00 lbs. .57 psi	
5"	14.620	14.627	.04	73.14 lbs. .25 psi	109.7 lbs. .38 psi	146.27 lbs. .51 psi	
		23.2	.07	116.00 lbs. .40 psi	174.00 lbs. .60 psi	232.00 lbs. .80 psi	
6"	18.970	18.98	.05	94.49 lbs. .33 psi	142.35 lbs. .49 psi	189.80 lbs. .66 psi	
		31.5	.09	157.50 lbs. .55 psi	236.25 lbs. .82 psi	315.00 lbs. 1.09 psi	
8"	28.55	28.567	.08	142.84 lbs. .50 psi	214.25 lbs. .74 psi	285.67 lbs. .99 psi	
		50.1	.14	250.00 lbs. .87 psi	375.75 lbs. 1.30 psi	501.00 lbs. 1.74 psi	
10"	40.48	40.507	.12	202.54 lbs. .70 psi	303.80 lbs. 1.05 psi	405.07 lbs. 1.41 psi	
		74.6	.21	373.00 lbs. 1.30 psi	559.50 lbs. 1.94 psi	746.00 lbs. 2.60 psi	

PSI is in pounds per square inch on models 6-RAH-7 BASE, which contain 2 bases for a total of 288 square inches of roof contact area support.

Chart of Usual Pipe Diameters

PIPE	PVC (Steel Size)	PVC (C900)	Cast Iron	Steel	Conduit
Inside Diameter	Outside Diameter	Outside Diameter	Outside Diameter	Outside Diameter	Outside Diameter
½"	.84"	–	–	.84"	.840"
¾"	1.05"	–	–	1.05"	1.050"
1"	1.32"	–	–	1.32"	1.315"
1 ¼"	1.66"	–	–	1.66"	1.660"
1 ½"	1.90"	–	–	1.90"	1.90"
2"	2.38"	2.50"	2.50"	2.38"	2.375"
2 ½"	2.88"	–	–	2.88"	2.875"
3"	3.50"	–	3.96"	3.50"	3.500"
3 ½"	–	–	–	–	4.000"
4"	4.50"	4.80"	5.00"	4.50"	4.500"
5"	–	–	–	5.56"	5.563"
6"	6.63"	6.90"	7.22"	6.63"	6.625"
8"	8.63"	9.05"	9.42"	8.63"	–
10"	10.75"	11.10"	11.60"	10.75"	–

The above dimensions are for usual and customary pipe sizes. Actual pipe sizes may vary from manufacturer to manufacturer.

Unipier Specifications for Typical Bases

Base Model	Outside Dimension in Inches at Roof Contact	Roof Contact Area in Inches Squared	Allowable Loading in Pounds	PSI on Roof for Each Base Under Maximum Load	Composition of Material of Base
1.5	6 X 6	24.42	80	3.27	P
1.5 SPACER	6 X 6	33.06	80	2.41	P
3-R-2	7.75 X 7.75	39.64	100	2.52	P
3-R-4	7.75 X 7.75	39.64	100	2.52	P
3-R SPACER	7.25 X 7.25	52.56	100	1.90	P
3-RAH-7	7.5 X 10	57.50	100	1.73	P
3-RAH-12	9 X 15.25	111.75	100	1.11	P
3-RAH-7 HDG / SS	8 X 14	96.06	100	1.04	HDG / SS
4-R	7.5 X 10	57.50	125	2.17	P
4-RAH-7	7.5 X 10	57.50	125	2.17	P
4-RAH-12	9 X 15.25	111.75	125	1.11	P
4-RAH-7 HDG / SS	12 X 16	174.89	150	0.85	HDG / SS
5-R	9 X 15.25	111.75	150	1.34	P
5-RAH-7	9 X 15.25	111.75	150	1.34	P
5-RAH-12	9 X 15.25	111.75	150	1.34	P
6-RAH-7	16 X 18	220.32	250	1.13	P
6-RAH-12	16 X 18	220.32	250	1.13	P
6-RAH-7 HDG / SS	12 X 16	174.89	150	0.85	HDG / SS
6-RAH-RS HDG / SS	12 X 16	174.89	150	0.85	HDG / SS
2.5-CS-2	7.5 X 10	57.50	100	1.73	P
2.5-CS-5	7.5 X 10	57.50	100	1.73	P
2.5-CS-7	7.5 X 10	57.50	100	1.73	P
2.5-CS-12	9 X 15.25	111.75	100	0.89	P
12-BS-7 HDG / SS	12 X 16	174.89	150	0.85	HDG / SS
16-BS-7	9 X 15.25	111.75	125	1.11	P
16-BS-12	9 X 15.25	111.75	125	1.11	P
16-BS-7 HDG / SS	12 X 16	174.89	150	0.85	HDG / SS
20-BS-7	16 X 18	220.32	250	1.13	P
20-BS-12	16 X 18	220.32	250	1.13	P
2.5-SB-H P	9 X 15.25	111.75	125	1.11	P
5-SB-H HDG	12 X 16	174.89	170	0.97	HDG / SS
5-SB-H P	16 X 18	220.32	250	1.13	P
6-H (2 Bases) P	9 X 15.25	223.50	310	1.38	P
6-H (2 Bases) HDG / SS	8 X 14	192.12	310	1.61	HDG / SS
8-H-SB (2 Bases) P	16 X 18	440.64	700	1.58	P
8-H-DB (2 Bases) P	9 X 31.69	447.00	700	1.56	P
8-H (2 Bases) HDG / SS	12 X 16	349.78	700	2.00	HDG / SS
16-H (2 Bases) P	16 X 39	881.28	1600	1.81	P
16-H (2 Bases) HDG / SS	20 X 20	800.00	1600	2.00	HDG / SS

P – Polycarbonate Resin, SS – Stainless Steel - ASTM No. 304, HDG – Hot-Dipped Galvanized

Note: Care should be taken to properly engineer the roof design so as to not overload the actual limits or manufacturer's recommended limits for each pipe support, the roof membrane, the roof top insulation, or the roof structure.

Note: Unipier has set the above load limits for each base to come within usual and customary roof structure, roof insulation, and roof membrane load limits. Unipier's manufacturing recommendations do not replace actual engineering required for each specific job.



Technical Properties For Polycarbonate Resin*

PROPERTY	ASTM TEST METHOD	VALUE
PHYSICAL		
Specific Gravity	D792	1.20
Specific Volume, in ³ /lb (cm ³ /g)	–	23.1 (0.83)
Weight/Volume, lbs/in ³ (g/cm ³)	–	0.043 (1.20)
Water Absorption %	D570	–
24 hours @ 73°F (23°C)	–	0.15
Equilibrium, 73°F (23°C)	–	0.35
Equilibrium, 212°F (100°C)	–	0.58
Mold Shrinkage, in/in (mm/mm)	D955	0.005-0.007
Light Transmittance, % at 0.125"	D1003	89
Haze, % @ 0.125"	D1003	1
Refractive Index	–	1.586
THERMAL		
Deflection Temperature °F (°C)	D648	–
@ 66 psi (0.46 MPa)	–	–
@ 254 psi (1.82 MPa)	–	270 ()
Specific Heat, Btu/lb/°F (kJ/kg/°K)	–	0.30 (1.25)
Thermal Conductivity	–	–
Btu-in/h-ft ² -°F (W/Km)	–	1.35 (.19)
Coefficient of Thermal Expansion	–	–
in/in/°F (m.m/°C)	D696	3.75 x 10 ⁻⁵ (6.75 s 10 ⁻⁵)
Vicat Softening Temperature, °F (°C)	D1525	305-315 (152-157)
Viscosity Midpoint	D1238	9.5
(Melt Flow Rate) g/10 min.	Condition 0	–
Brittleness Temperature, °F (°C)	D746	<-200 (-129)
Flammability Ratings	–	–
ASTM	D365°	AEB>1"
UL Standard 94° 1/16 (1.6 mm)	UL94	V-2
UL Standard 94° 1/8" (3.2 mm)	UL94	V-2
Oxygen Index	D2863	25.0
PHYSICAL		
Dielectric Strength, volts/mil (kV/mm)	D149	380 (15.0)
Short time, 125 mils (3.2mm)	–	–
Dielectric Constant	D150	–
60 Hz	–	3.17
106 Hz	–	2.96
Dielectric Factor	D150	–
60 Hz	–	0.0009
106 Hz	–	0.010
Volume Resistivity, ohm-cm	–	D257
@ 73°F, dry (23°C)	–	>10 ¹⁶
Arc Resistance, sec	D495	–
Stainless Steel Electrodes	–	10-11
Tungsten Electrodes	–	120

PROPERTY	ASTM TEST METHOD	VALUE
MECHANICAL		
Tensile Strength, psi (MPa)	D638	–
Yield	–	9,000 (62)
Ultimate	–	10,000 (69)
Elongation, %	D638	–
Rupture	–	130
Flexural Strength, psi (MPa)	D790	14,000 (97)
Flexural Modules, 10 ⁵ psi (MPa)	D790	3.40 (2,300)
Compressive Strength, psi (MPa)	D695	12,500 (86)
Compressive Modules, psi (MPa)	D695	–
10 ⁵ osu (MPa)	–	3.45 (2,400)
Shear Strength, psi (MPa)	D732	–
Yield	–	6,000 (40)
Ultimate	–	10,000 (70)
Shear Modules, 10 ⁵ psi (MPa)	–	1.14 (790)
Izod Impact Strength, ft-lbs/in (J/m)	D1822	–
Notched, 1/8" thick (3.22mm)	–	15 (801)
Tensile Impact Strength, ft-lbs/in ² (kJ/m ²)	D1822	–
S-type	–	275 (579)
Dynatup Impact Strength, ft-lbs/in (J)	D3763	47 (64)
Fatigue Strength, psi @ 2.5mm	D671	–
cycles (MPa)	–	1,000 (7.0)
Rockwell Hardness	D785	–
M	–	70
R	–	118
Deformation Under Load %	D621	–
4000 psi @ 73°F (27 MPa @ 23°C)	–	0.2
4000 psi @ 158°F (27 MPa @ 70°C)	–	0.5
Taber Abrasion Resistance	–	–
Weight Loss, mg/1000 cycles	D1044	10

*Polycarbonate Resin is used in models:

1.5	5-R
1.5 Spacer	5-RAH-7
	5-RAH-12
2.5-CS-2	
2.5-CS-5	6-RAH-7
2.5-CS-7	6-RAH-12
2.5-CS-12	6-H P
2.5-SB-H	6-DSA
	6-DS P
3-R-2	
3-R-4	8-DSA
3-R Spacer	8-DS P.
3-RAH-7	
3-RAH-12	16-BS-7
	16-BS-12
4-R	16-H P
4-RAH-7	
4-RAH-12	All Rollers
4-DSA	

Electrical & Support Division



Conduit Systems	Cable Systems	Framing Systems	Cable Tray Systems
<p>Steel Conduit</p> <ul style="list-style-type: none"> • Rigid (GRC) • IMC <p>Aluminum Conduit</p> <ul style="list-style-type: none"> • Rigid • Aluminum Elbows • Aluminum Couplings <p>Steel EMT</p> <ul style="list-style-type: none"> • True Color™ EMT • Fire Alarm™ EMT • Blue EMT • E-Z Pull™ EMT <p>Kwik Products</p> <ul style="list-style-type: none"> • Kwik-Fit™ EMT (built-in set-screw coupling) • Kwik-Couple™ IMC/GRC (built-in 3 piece rotating coupling) • Kwik-Fit™ Compression EMT (built-in compression fitting) <p>PVC</p> <ul style="list-style-type: none"> • Rigid PVC • Schedule - 40 & 80 Products • EB/DB Duct • Fittings, Spacers & Accessories <p>Columbia-MBF™</p> <p>Conduit Systems Canada</p> <p>All items listed above, except for the following:</p> <ul style="list-style-type: none"> • IMC • Kwik-Couple • PVC 	<p>AC & MC Cable</p> <ul style="list-style-type: none"> • MC TUFF™ Lightweight Steel (MC) Cable • MC TUFF™ IG (MC) Cable with Isolated Ground • MC Lite™ Metal Clad Aluminum (MC) Cable • MC-Quik™ (MC) Cable • MC-Stat™ (MC) Cable • MC-Plus™ (MC) Cable • HCF-90™ & HCF-Lite™ • AC-90™ & AC-Lite™ • Fire Alarm™ Cable • Home Run Cable™ • Parking Deck/Lot Cable™ • Super Neutral Cable™ <p>Flexible Conduit</p> <ul style="list-style-type: none"> • LIQUID-TUFF™ Liquid-Tight Flexible Conduit • Full and Reduced Wall Flexible Metal Conduit <p>Fittings</p> <ul style="list-style-type: none"> • EMT Steel Compression & Set-Screw Fittings • Liquid-Tight Metallic & Non-Metallic Fittings • MC/AC Cable Connectors <p>AFC Accessories</p> <ul style="list-style-type: none"> • Lighting, Power, & Appliance Whips • Temp-Lites™ • Bare Armored Ground <p>ACS/Uni-Fab</p> <ul style="list-style-type: none"> • Modular Lighting Systems • Raised Floor Assemblies • Pre-Fab Assemblies 	<p>Channel</p> <ul style="list-style-type: none"> • Steel Channel • Aluminum Channel • Stainless Steel Channel • Fiberglass Channel • Junior Channel <p>Fittings & Accessories</p> <ul style="list-style-type: none"> • Channel Brackets • Channel Fittings • Pipe Clamps • Threaded Rods • Fiberglass Fittings • Junior Channel Fittings • Concrete Inserts • Slotted Angles <p>Finishes</p> <ul style="list-style-type: none"> • Pre-Galvanized Channel • Green Channel • Hot-Dip Galv. Channel • Gold Channel <p>Solar Products</p> <p>UNISTRUT®</p> <p>Framing Systems</p> <p>All items listed above, plus the following:</p> <p>Gratings</p> <p>Roof Walks</p> <p>Solar Products</p> <p>Telestrut® Telescoping Strut System</p> <p>UniPier®</p> <p>Rooftop Supports</p>	<p>Aluminum Tray</p> <ul style="list-style-type: none"> • Aluminum Ladder Tray • Aluminum Hat Tray • Aluminum Trof Tray • Aluminum Channel • Aluminum Fittings <p>Steel Tray</p> <ul style="list-style-type: none"> • Steel Ladder Tray • Steel Hat Tray • Steel Trof Tray • Steel Channel • Steel Fittings <p>I-Beam™ Cable Tray</p> <ul style="list-style-type: none"> • I-BEAM™ Aluminum Tray • I-BEAM™ Accessories <p>Fiberglass Tray</p> <ul style="list-style-type: none"> • Cope-glas™ Fiberglass Tray • Fiberglass Fittings <p>Wire Basket</p> <ul style="list-style-type: none"> • CAT TRAY™ Wire Basket • CAT TRAY™ Accessories <p>Center Hung Tray</p> <ul style="list-style-type: none"> • Centipede™ Center Hung Tray • Centipede™ Accessories <p>Other Cope Products</p> <ul style="list-style-type: none"> • Cable Channel

Unistrut International

16100 South Lathrop Avenue

Harvey, IL 60426

PHONE / 800-882-5543

FAX / 708-339-0615

www.unistrut.com



Columbia-MBF™



KAF-TECH®



COPE®



UNISTRUT®
Construction

