

GENERAL INFORMATION

PURE110+®

Epoxy Injection Adhesive Anchoring System

PRODUCT DESCRIPTION

The Pure110+ is a two-component, high strength adhesive anchoring system. The system includes injection adhesive in plastic cartridges, mixing nozzles, dispensing tools and hole cleaning equipment. The Pure110+ is designed for bonding threaded rod and reinforcing bar hardware into drilled holes in concrete and masonry base materials.

Pure110+ has the same bond strength at room temperature and at 110°F.

GENERAL APPLICATIONS AND USES

- Bonding threaded rod and reinforcing bar into hardened concrete
- Evaluated for installation and use in dry and wet holes, including water filled and underwater
- Can be installed in a wide range of base material temperatures

FEATURES AND BENEFITS

- + Designed for use with threaded rod and reinforcing bar hardware elements
- + Evaluated and recognized for freeze/thaw performance
- + Cartridge design allows for multiple uses using extra mixing nozzles
- + Mixing nozzles proportion adhesive and provide simple delivery method into drilled holes
- + Evaluated and recognized for long term and short term loading (see performance tables)
- + Same bond strength at room temperature and at 110°F.

APPROVALS AND LISTINGS

- International Code Council, Evaluation Service (ICC-ES) ESR-3298 for cracked and uncracked concrete
- Code Compliant with 2015 IBC, 2015 IRC, 2012 IBC, 2012 IRC, 2009 IBC, and 2009 IRC.
- Conforms to requirements of ASTM C 881, Types I, II, IV and V, Grade 3, Classes B & C (also meets Type III except for elongation)
- Department of Transportation listings – see www.DeWALT.com or contact transportation agency
- Tested in accordance with ACI 355.4, ASTM E 488, and ICC-ES AC308 for use in structural concrete (Design according to ACI 318-14, Chapter 17 and ACI 318-11/08 Appendix D)
- Evaluated and qualified by an accredited independent testing laboratory for recognition in cracked and uncracked concrete including seismic and wind loading.
- Compliant with NSF/ANSI 61 for drinking water system components - health effects; minimum requirements for materials in contact with potable water and water treatment

GUIDE SPECIFICATIONS

CSI Divisions: 03 16 00 - Concrete Anchors, 04 05 19.16 Masonry Anchors and 05 05 19 Post-Installed Concrete Anchors. Adhesive anchoring system shall be Pure110+ as supplied by DeWALT, Towson, MD. Anchors shall be installed in accordance with published instructions and requirements of the Authority Having Jurisdiction.



CODE LISTED
ICC-ES ESR-3298
CONCRETE

SECTION CONTENTS

General Information..... 1
 Reference Data (ASD).....2
 Strength Design (SD).....6
 Installation Instructions (Solid Base Materials) 14
 Installation Instructions (Hollow Base Materials) 16
 Reference Installation Tables 17
 Ordering Information..... 18



PACKAGING

Coaxial Cartridge

- 9 fl. oz. (265 ml or 16.2 in³)

Dual (side-by-side) Cartridge

- 21 fl. oz. (620 ml or 37.8 in³), 1:1 mix ratio
- 13 fl. oz. (385 ml or 23.5 in³), 3:1 mix ratio
- 20 fl. oz. (585 ml or 35.7 in³), 3:1 mix ratio

STORAGE LIFE & CONDITIONS

Dual cartridge: Two years
 Coaxial cartridge: Eighteen months
 In a dry, dark environment with temperature ranging from 41°F to 90°F (5°C to 32°C)

ANCHOR SIZE RANGE (TYP.)

- 3/8" to 1-1/4" diameter threaded rod
- No. 3 to No. 10 reinforcing bar (rebar)

SUITABLE BASE MATERIALS

- Normal-weight concrete
- Lightweight concrete
- Grouted Concrete Masonry
- Hollow Concrete Masonry

PERMISSIBLE INSTALLATION CONDITIONS (ADHESIVE)

- Dry concrete
- Water-saturated concrete (wet)
- Water-filled holes (flooded)
- Underwater concrete (submerged)

REFERENCE DATA (ASD)

Installation Table for Pure110+ (Solid Concrete Base Materials)

Dimension/Property	Notation	Units	Nominal Anchor Size								
			3/8	1/2	5/8	3/4	7/8	1	-	1-1/4	-
Threaded Rod	-	-	3/8	1/2	5/8	3/4	7/8	1	-	1-1/4	-
Reinforcing Bar	-	-	#3	#4	#5	#6	#7	#8	#9	-	#10
Nominal anchor diameter	d	in. (mm)	0.375 (9.5)	0.500 (12.7)	0.625 (15.9)	0.750 (19.1)	0.875 (22.5)	1.000 (25.4)	1.125 (28.6)	1.250 (31.8)	1.250 (31.8)
Carbide drill bit nominal size	d _{bit}	in.	7/16 ANSI	9/16 ANSI	11/16 or 3/4 ANSI	7/8 ANSI	1 ANSI	1-1/8 ANSI	1-3/8 ANSI	1-3/8 ANSI	1-1/2 ANSI
Minimum embedment	h _{nom}	in. (mm)	2-3/8 (61)	2-3/4 (70)	3-1/8 (80)	3-1/2 (89)	3-1/2 (89)	4 (102)	4-1/2 (114)	5 (127)	5 (127)
Minimum spacing distance	s _{min}	in. (mm)	1-7/8 (48)	2-1/2 (62)	3-1/8 (80)	3-3/4 (95)	4-3/8 (111)	5 (127)	5-5/8 (143)	6-1/4 (159)	6-1/4 (159)
Minimum edge distance	c _{min}	in. (mm)	1-7/8 (48)	2-1/2 (62)	3-1/8 (80)	3-3/4 (95)	4-3/8 (111)	5 (127)	5-5/8 (143)	6-1/4 (159)	6-1/4 (159)
Maximum torque ¹	T _{max}	ft.-lb. (N-m)	15 (20)	30 (41)	60 (81)	105 (142)	125 (169)	165 (223)	200 (270)	280 (379)	280 (379)
Maximum torque (low strength rods) ^{1,2}		ft.-lb. (N-m)	5 (7)	20 (27)	40 (54)	60 (81)	100 (136)	165 (223)	-	280 (379)	-

1. Torque may not be applied to the anchors until the full cure time of the adhesive has been achieved.
 2. These torque values apply to ASTM A 36 / F 1554, Grade 36 carbon steel threaded rods; ASTM F1554 Grade 55 carbon steel threaded rods; and ASTM A193 Grade B8/B8M (Class 1) stainless steel threaded rods.

Installation Table for Pure110+ (Hollow Base Material with Screen Tube)

Dimensions/property	Notation	Units	Nominal Size - Plastic			
			3/8"	1/2"	5/8"	3/4"
Nominal threaded rod diameter	d	in (mm)	0.375 (9.5)	0.500 (12.7)	0.625 (15.9)	0.750 (19.0)
Nominal screen tube diameter	-	in.	3/8	1/2	5/8	3/4
Nominal diameter of drilled hole	d _{bit}	in.	9/16 ANSI	3/4 ANSI	7/8 ANSI	1 ANSI
Maximum torque (only possible after full cure time of adhesive)	T _{max}	ft.-lb. (N-m)	10 (8)	10 (8)	10 (8)	10 (8)

Detail of Steel Hardware Elements used with Injection Adhesive System

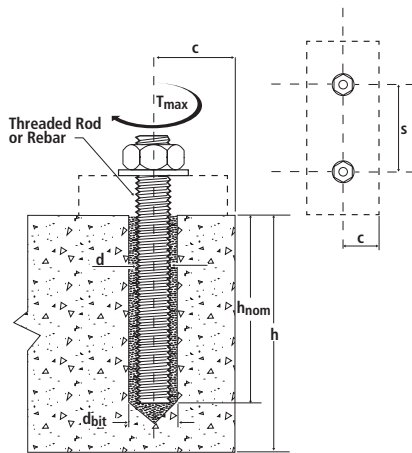

Nomenclature

- d = Diameter of anchor
- d_{bit} = Diameter of drilled hole
- h = Base material thickness
- h_{nom} = Minimum embedment depth
- The greater of: [h_{nom} + 1-1/4"] and [h_{nom} + 2d_{bit}]

Threaded Rod and Deformed Reinforcing Bar Material Properties

Steel Description (General)	Steel Specification (ASTM)	Nominal Anchor Size (inch)	Minimum Yield Strength, f _y (ksi)	Minimum Ultimate Strength, f _u (ksi)
Carbon Steel	A 36 or F1554 Grade 36	3/8 through 1-1/4	36.0	58.0
	F 1554 Grade 55		55.0	75.0
	A 449	3/8 through 1	92.0	120.0
		1-1/4	81.0	105.0
	A 193, Grade B7 or F 1554, Grade 105	3/8 through 1-1/4	105.0	125.0
F 568M Class 5.8	3/4 through 1-1/4	58.0	72.5	
Stainless Steel	F 593, Condition CW	3/8 through 5/8	65.0	100.0
		3/4 through 1-1/4	45.0	85.0
	A 193/A193M Grade B8/B8M2, Class 1	3/4 through 1-1/4	30.0	75.0
A 193/A193M Grade B8/B8M2, Class 2B	3/8 through 1-1/4	75.0	95.0	
Grade 40 Reinforcing Bar	A 615, A 767	3/8 through 3/4 (#3 through #6)	40.0	60.0
Grade 60 Reinforcing Bar	A 615, A 767	3/8 through 1-1/4 (#3 through #10)	60.0	90.0
	A 706, A 767		60.0	80.0
Grade 75 Reinforcing Bar	A 615, A 767	3/8 through 1-1/4 (#3 through #10)	75.0	100.0

Ultimate and Allowable Load Capacities for Pure110+ Installed with Threaded Rod into Normal Weight Concrete (based on bond strength/concrete capacity)^{1,2,3,4,5,6,7}



Rod Diameter d in.	Drill Diameter d _{bit} in.	Minimum Embedment Depth in. (mm)	Minimum Concrete Compressive Strength			
			f'c = 3,000 psi (20.7 MPa)		f'c = 4,000 psi (27.6 MPa)	
			Ultimate Tension Load Capacity lbs. (kN)	Allowable Tension Load Capacity lbs. (kN)	Ultimate Tension Load Capacity lbs. (kN)	Allowable Tension Load Capacity lbs. (kN)
3/8	7/16	3-3/8 (85.7)	10,445 (46.5)	2,610 (11.6)	10,445 (46.5)	2,610 (11.6)
1/2	9/16	4 1/2 (114.3)	17,470 (77.7)	4,370 (19.4)	20,225 (90.0)	5,055 (22.5)
5/8	11/16 or 3/4	5-5/8 (142.9)	23,335 (103.8)	5,835 (26.0)	28,600 (127.2)	7,150 (31.8)
3/4	7/8	6-3/4 (171.5)	36,255 (161.3)	9,065 (40.3)	40,930 (182.1)	10,235 (45.5)
7/8	1	7-7/8 (200.0)	46,275 (205.8)	11,570 (51.5)	52,920 (235.4)	13,230 (58.8)
1	1-1/8	9 (228.6)	57,015 (253.6)	14,255 (63.4)	79,295 (352.7)	19,825 (88.2)
		10 (254.0)	77,445 (344.5)	19,360 (86.1)	82,745 (368.1)	20,685 (92.0)
1-1/4	1-3/8	11-1/4 (285.8)	91,885 (408.7)	22,970 (102.2)	98,170 (436.7)	24,545 (109.2)

1. Allowable load capacities listed are calculated using an applied safety factor of 4.0. Consideration of safety factors of 10 or higher may be necessary depending on the application, such as life safety or overhead.
2. Linear interpolation may be used to determine allowable loads for intermediate embedments and compressive strengths.
3. The tabulated load values are applicable to single anchors installed at critical edge and spacing distances and where the minimum member thickness is the greater of [h_{nom} + 1-1/4"] and [h_{nom} + 2d_{bit}].
4. The tabulated load values are applicable for dry concrete. Holes must be drilled with a hammer drill and an ANSI carbide drill bit. Installations in water-saturated concrete (wet) or in water-filled holes (flooded) require a 15% reduction in capacity. Installations in underwater concrete (submerged) require a 30% reduction in capacity. Contact DeWALT for more information concerning these installation conditions.
5. Adhesives experience reductions in capacity at elevated temperatures. See the in-service temperature chart for allowable load capacity reduction factors.
6. Allowable bond strength/concrete capacity must be checked against allowable steel strength in tension to determine the controlling allowable load.
7. Allowable shear capacity is controlled by allowable steel strength for the given conditions.

Ultimate and Allowable Load Capacities for Pure110+ Installed with Reinforcing Bar into Normal Weight Concrete (based on bond strength/concrete capacity)^{1,2,3,4,5,6,7}



Bar Diameter d #	Drill Diameter d _{bit} in.	Minimum Embedment Depth in. (mm)	Minimum Concrete Compressive Strength			
			f'c = 3,000 psi (20.7 MPa)		f'c = 4,000 psi (27.6 MPa)	
			Ultimate Tension Load Capacity lbs. (kN)	Allowable Tension Load Capacity lbs. (kN)	Ultimate Tension Load Capacity lbs. (kN)	Allowable Tension Load Capacity lbs. (kN)
#3	7/16	3-3/8 (85.7)	11,155 (49.6)	2,790 (12.4)	11,155 (49.6)	2,790 (12.4)
#4	9/16	4-1/2 (114.3)	17,735 (78.9)	4,435 (19.7)	19,200 (85.4)	4,800 (21.4)
#5	11/16 or 3/4	4 (101.6)	16,740 (74.5)	4,185 (18.6)	16,910 (75.2)	4,230 (18.8)
		5-5/8 (142.9)	23,420 (104.2)	5,855 (26.0)	25,705 (114.3)	6,425 (28.6)
#6	7/8	6-3/4 (171.5)	34,266 (152.4)	8,565 (38.1)	40,775 (181.4)	10,195 (45.3)
#8	1-1/8	9 (228.6)	55,140 (245.3)	13,785 (61.3)	72,575 (322.8)	18,145 (80.7)

1. Allowable load capacities listed are calculated using an applied safety factor of 4.0. Consideration of safety factors of 10 or higher may be necessary depending on the application, such as life safety or overhead.
2. Linear interpolation may be used to determine allowable loads for intermediate embedments and compressive strengths.
3. The tabulated load values are applicable to single anchors installed at critical edge and spacing distances and where the minimum member thickness is The greater of [h_{nom} + 1-1/4"] and [h_{nom} + 2d_{bit}].
4. The tabulated load values are applicable for dry concrete. Holes must be drilled with a hammer drill and an ANSI carbide drill bit. Installations in water-saturated concrete (wet) or in water-filled holes (flooded) require a 15% reduction in capacity. Installations in underwater concrete (submerged) require a 30% reduction in capacity. Contact DeWALT for more information concerning these installation conditions.
5. Adhesives experience reductions in capacity at elevated temperatures. See the in-service temperature chart for allowable load capacity reduction factors.
6. Allowable bond strength/concrete capacity must be checked against allowable steel strength in tension to determine the controlling allowable load.
7. Allowable shear capacity is controlled by allowable steel strength for the given conditions.



Allowable Load Capacities for Pure110+ Installed into Uncracked Normal-Weight Concrete with Threaded Rod and Reinforcing Bar (Based on Steel Strength)^{1,2,3}

Nominal Rod Diameter or Rebar Size (in. or #)	Steel Elements - Threaded Rod and Reinforcing Bar									
	A36 or F1554, Grade 36		A 193, Grade B7 or F1554, Grade 105		F 593, CW (SS)		Grade 60 Rebar		Grade 40 Rebar	
	Tension lbs (kN)	Shear lbs (kN)	Tension lbs (kN)	Shear lbs (kN)	Tension lbs (kN)	Shear lbs (kN)	Tension lbs (kN)	Shear lbs (kN)	Tension lbs (kN)	Shear lbs (kN)
3/8 or #3	2,115 (9.4)	1,090 (4.8)	4,555 (20.3)	2,345 (10.4)	3,645 (16.2)	1,880 (8.4)	3,280 (14.6)	1,690 (7.5)	2,185 (9.7)	1,125 (5.0)
1/2 or #4	3,760 (16.7)	1,935 (8.6)	8,100 (36.0)	4,170 (18.5)	6,480 (28.8)	3,340 (14.9)	5,830 (25.9)	3,005 (13.4)	3,890 (17.3)	2,005 (8.9)
5/8 or #5	5,870 (26.1)	3,025 (13.5)	12,655 (56.3)	6,520 (29.0)	10,125 (45.0)	5,215 (23.2)	9,110 (40.5)	4,695 (20.9)	6,075 (27.0)	3,130 (13.9)
3/4 or #6	8,455 (37.6)	4,355 (19.4)	18,225 (81.1)	9,390 (41.8)	12,390 (55.1)	6,385 (28.4)	13,120 (58.4)	6,760 (30.1)	8,745 (38.9)	4,505 (20.0)
7/8 or #7	11,510 (51.2)	5,930 (26.4)	24,805 (110.3)	12,780 (56.8)	16,865 (75.0)	8,690 (38.7)	17,860 (79.4)	9,200 (40.9)	11,905 (53.0)	6,135 (27.3)
1 or #8	15,035 (66.9)	7,745 (34.5)	32,400 (144.1)	16,690 (74.2)	22,030 (98.0)	11,350 (50.5)	23,325 (103.8)	12,015 (53.4)	15,550 (69.2)	8,010 (35.6)
#9	-	-	-	-	-	-	29,680 (132.0)	15,290 (68.0)	19,785 (88.0)	10,195 (45.3)
1-1/4	23,490 (104.5)	12,100 (53.8)	50,620 (225.2)	26,080 (116.0)	34,425 (153.1)	17,735 (78.9)	-	-	-	-
#10	-	-	-	-	-	-	37,625 (167.4)	19,380 (86.2)	25,080 (111.6)	12,920 (57.5)

1. AISC defined steel strength (ASD): Tensile = $0.33 \cdot F_u \cdot A_{nom}$, Shear = $0.17 \cdot F_u \cdot A_{nom}$
 2. Allowable steel strength in tension must be checked against allowable bond strength/concrete capacity in tension to determine the controlling allowable load.
 3. The tabulated load values are applicable to single anchors installed at critical edge and spacing distances and where the minimum member thickness is the greater of $[h_{nom} + 1 - 1/4"]$ and $[h_{nom} + 2d_{bar}]$.

In-Service Temperature Chart For Allowable Load Capacities¹

BASE MATERIAL TEMPERATURE		REDUCTION FACTOR FOR TEMPERATURE
°F	°C	
32	0	0.89
41	5	1.00
50	10	1.00
70	20	1.00
110	43	1.00
130	54	0.82
150	66	0.73
180	82	0.48

1. Linear interpolation may be used to derive reduction factors for temperatures between those listed.

ADHESIVES

PURE110+[®]
Epoxy Injection Adhesive Anchoring System

Ultimate and Allowable Load Capacities for Threaded Rod Installed with Pure110+ into Grout Filled Masonry^{1,2,3,4,5}



Anchor Installed into Grouted Masonry Wall Faces								
Nominal Diameter d in.	Minimum Embed. h _v in. (mm)	Nominal Drill Bit Diameter in.	Minimum End Distance in. (mm)	Minimum Edge Distance in. (mm)	Ultimate Load		Allowable Load	
					Tension lbs. (kN)	Shear lbs. (kN)	Tension lbs. (kN)	Shear lbs. (kN)
3/8	3 (76.2)	7/16 ANSI	12 (304.8)	12 (304.8)	6,005 (26.7)	5,200 (23.1)	1,200 (5.3)	1,040 (4.6)
1/2	4 (101.6)	9/16 ANSI	12 (304.8)	12 (304.8)	8,650 (38.5)	8,845 (39.3)	1,730 (7.7)	1,770 (7.9)
5/8	5 (127)	11/16 ANSI	12 (304.8)	12 (304.8)	12,840 (57.1)	8,430 (37.5)	2,570 (11.4)	1,685 (7.5)
3/4	6 (152.4)	7/8 ANSI	20 (508)	20 (508)	19,560 (87.0)	12,685 (56.4)	3,910 (17.4)	2,540 (11.3)

Anchor Installed in the Tops of Grouted Masonry Walls ⁶								
Nominal Diameter d in.	Minimum Embed. h _v in. (mm)	Nominal Drill Bit Diameter in.	Minimum End Distance in. (mm)	Minimum Edge Distance in. (mm)	Ultimate Load		Allowable Load	
					Tension lbs. (kN)	Shear lbs. (kN)	Tension lbs. (kN)	Shear lbs. (kN)
1/2	4 (101.6)	9/16 ANSI	4 (101.6)	1.75 (44.5)	5,135 (22.8)	1,750 (7.8)	1,030 (4.6)	350 (1.6)
5/8	5 (127)	11/16 ANSI	4 (101.6)	2.75 (69.9)	5,360 (23.6)	3,130 (13.9)	1,070 (4.8)	625 (2.8)

1. Tabulated load values are for 3/8" and 1/2" diameter anchors installed in minimum 6" wide, Grade N, Type II, light weight concrete masonry units conforming to ASTM C 90 that have reached the minimum designated ultimate compressive strength at the time of installation ($f'_m \geq 1,500$ psi).
2. Tabulated load values are for 5/8" and 3/4" diameter anchors installed in 8" wide, Grade N, Type II, light weight concrete masonry units conforming to ASTM C 90 that have reached the minimum designated ultimate compressive strength at the time of installation ($f'_m \geq 1,500$ psi).
3. Anchors must be installed in grouted cells and the minimum edge and end distances must be maintained.
4. Allowable load capacities listed are calculated using an applied safety factor of 5.0 and must be checked against the allowable tension and shear capacities for threaded rod based on steel strength to determine the controlling factor.
5. The tabulated values are applicable for anchors installed into grouted masonry wall faces and masonry wall tops at a critical spacing distance, s_w , between anchors of 3 times the embedment depth.
6. Anchor installations into tops of grouted masonry walls are limited to one per masonry cell.

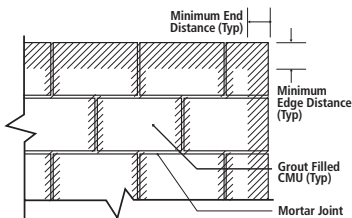

Wall Face
Permissible Anchor Locations
(Un-hatched Area)

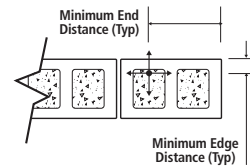

Top of Wall

Ultimate and Allowable Load Capacities for Threaded Rod Installed with Pure110+ in Hollow Concrete Masonry Walls with Plastic Screen Tubes^{1,2,3}



Nominal Anchor Diameter in.	Minimum Screen Tube Length in.	Minimum End Distance in. (mm)	Minimum Edge Distance in. (mm)	ASTM C-90 Block Type	Ultimate Load	Allowable Load
					Tension lbs. (kN)	Tension lbs. (kN)
3/8	3-1/2	3-3/4 (95.3)	3-3/4 (95.3)	Lightweight	790 (3.5)	160 (0.7)
1/2	3-1/2	3-3/4 (95.3)	3-3/4 (95.3)	Lightweight	1,255 (5.6)	250 (1.1)
5/8	6	3-3/4 (95.3)	3-3/4 (95.3)	Normal-weight*	1,545 (6.9)	310 (1.4)
3/4	6	3-3/4 (95.3)	3-3/4 (95.3)	Normal-weight*	1,545 (6.9)	310 (1.4)

1. Tabulated load values are for anchors installed in minimum 8" wide, Grade N, Type II, lightweight or normal weight concrete masonry units conforming to ASTM C 90 that have reached a designated ultimate compressive strength at the time of installation ($f'_m \geq 1,500$ psi). Mortar must be type N, S or M.
2. Allowable loads are calculated using an applied safety factor of 5.0. Consideration of safety factors of 10 or higher may be necessary depending on the application, such as life safety.
3. Anchor spacing is limited to one per masonry cell.
4. The tabulated load values are applicable to normal-weight concrete masonry units with a minimum face shell thickness of 1-1/2 inches.

STRENGTH DESIGN (SD)

Installation Specifications for Threaded Rod and Reinforcing Bar¹

CODE LIST-ED



Parameter	Symbol	Units	Fractional Nominal Rod Diameter (Inch) / Reinforcing Bar Size								
			3/8 or #3	1/2 or #4	5/8 or #5	3/4 or #6	7/8 or #7	1 or #8	#9	1-1/4	#10
Threaded rod outside diameter	d	inch (mm)	0.375 (9.5)	0.500 (12.7)	0.625 (15.9)	0.750 (19.1)	0.875 (22.2)	1.000 (25.4)	-	1.250 (31.8)	-
Rebar nominal outside diameter	d	inch (mm)	0.375 (9.5)	0.500 (12.7)	0.625 (15.9)	0.750 (19.1)	0.875 (22.2)	1.000 (25.4)	1.125 (28.7)	-	1.250 (31.8)
Carbide drill bit nominal size	d _o (d _{bit})	inch	7/16	9/16	11/16 or 3/4	7/8	1	1-1/8	1-3/8	1-3/8	1-1/2
Minimum embedment	h _{ef,min}	inch (mm)	2-3/8 (60)	2-3/4 (70)	3-1/8 (79)	3-1/2 (89)	3-1/2 (89)	4 (102)	4-1/2 (114)	5 (127)	5 (127)
Maximum embedment	h _{ef,max}	inch (mm)	7-1/2 (191)	10 (254)	12-1/2 (318)	15 (381)	17-1/2 (445)	20 (508)	22-1/2 (572)	25 (635)	25 (635)
Minimum member thickness	h _{min}	inch (mm)	h _{ef} + 1-1/4 (h _{ef} + 30)			h _{ef} + 2d _o					
Minimum anchor spacing	s _{min}	inch (mm)	1-7/8 (48)	2-1/2 (64)	3-1/8 (79)	3-3/4 (95)	4-3/8 (111)	5 (127)	5-5/8 (143)	6-1/4 (159)	6-1/4 (159)
Minimum edge distance	c _{min}	inch (mm)	1-7/8 (48)	2-1/2 (64)	3-1/8 (79)	3-3/4 (95)	4-3/8 (111)	5 (127)	5-5/8 (143)	6-1/4 (159)	6-1/4 (159)
Max. torque ²	T _{max}	ft-lbs (N-m)	15 (20)	30 (41)	60 (81)	105 (142)	125 (169)	165 (221)	200 (280)	280 (379)	280 (379)
Max. torque ^{2,3} (low strength rods)	T _{max}	ft-lbs (N-m)	5 (7)	20 (27)	40 (54)	60 (81)	100 (136)	165 (223)	-	280 (379)	-
Minimum edge distance, reduced ⁵	c _{min,red}	inch (mm)	1-3/4 (45)	1-3/4 (45)	1-3/4 (45)	1-3/4 (45)	1-3/4 (45)	1-3/4 (45)	2-3/4 (70)	2-3/4 (70)	2-3/4 (70)
Max. torque, reduced ²	T _{max,red}	ft-lbs (N-m)	7 [5] ⁴	14 (19)	27 (37)	47 (64)	56 (76)	74 (100)	90 (122)	126 (171)	126 (171)

For pound-inch units: 1 mm = 0.03937 inch, 1 N-m = 0.7375 ft-lbf. For SI: 1 inch = 25.4 mm, 1 ft-lbf = 1.356 N-m.

- For use with the design provisions of ACI 318-14 Ch.17 or ACI 318-11 Appendix D as applicable, ICC-ES AC308, Section 4.2 and ESR-3298
- Torque may not be applied to the anchors until the full cure time of the adhesive has been achieved.
- These torque values apply to ASTM A 36 / F 1554 Grade 36 carbon steel threaded rods; ASTM F 1554 Grade 55 carbon steel threaded rods; and ASTM A 193 Grade B8/B8M (Class 1) stainless steel threaded rods.
- These torque values apply to ASTM A 193 Grade B8/B8M (Class 1) stainless steel threaded rods.
- For installation between the minimum edge distance, c_{min}, and the reduced minimum edge distance, c_{min,red}, the maximum torque applied must be max torque reduced, T_{max,red}.

Detail of Steel Hardware Elements used with Injection Adhesive System

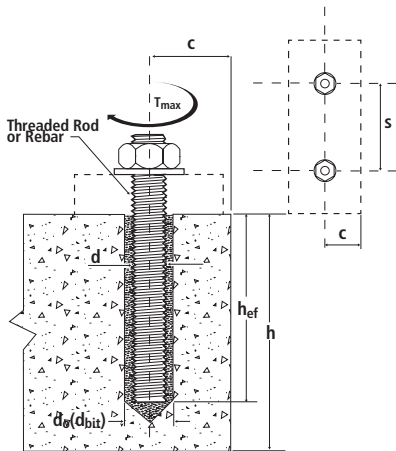

Threaded Rod and Deformed Reinforcing Bar Material Properties

Steel Description (General)	Steel Specification (ASTM)	Nominal Anchor Size (inch)	Minimum Yield Strength, f _y (ksi)	Minimum Ultimate Strength, f _u (ksi)
Carbon rod	A 36 or F 1554 Grade 36	3/8 through 1-1/4	36.0	58.0
	F 1554 Grade 55		55.0	75.0
	A 449	3/8 through 1	92.0	120.0
		1-1/4	81.0	105.0
	A 193, Grade B7 or F 1554, Grade 105	3/8 through 1-1/4	105.0	125.0
Stainless rod	F 593 Condition CW	3/8 through 5/8	65.0	100.0
		3/4 through 1-1/4	45.0	85.0
	A 193/A193M Grade B8/B8M, Class 1	3/8 through 1-1/4	30.0	75.0
	A 193/A193M Grade B8/B8M2, Class 2B	3/8 through 1-1/4	75.0	95.0
Grade 40 Reinforcing Bar	A 615, A 767	3/8 through 1-1/4 (#3 through #10)	40.0	60.0
Grade 60 Reinforcing Bar	A 615, A 767	3/8 through 1-1/4 (#3 through #10)	60.0	90.0
	A 706, A 767		60.0	80.0
Grade 75 Reinforcing Bar	A 615, A 767	3/8 through 1-1/4 (#3 through #10)	75.0	100.0

ADHESIVES

PURE110+[®]
Epoxy Injection Adhesive Anchoring System

**Steel Tension and Shear Design for Threaded Rod in Normal Weight Concrete
(For use with load combinations taken from ACI 318-14 Section 5.3)**

**CODE LIST-
ED**



Design Information		Symbol	Units	Nominal Rod Diameter ^a (inch)						
				3/8	1/2	5/8	3/4	7/8	1	1-1/4
Threaded rod nominal outside diameter		d	inch (mm)	0.375 (9.5)	0.500 (12.7)	0.625 (15.9)	0.750 (19.1)	0.875 (22.2)	1.000 (25.4)	1.250 (31.8)
Threaded rod effective cross-sectional area		A _{se}	inch ² (mm ²)	0.0775 (50)	0.1419 (92)	0.2260 (146)	0.3345 (216)	0.4617 (298)	0.6057 (391)	0.9691 (625)
ASTM A 36 and ASTM F 1554 Grade 36	Nominal strength as governed by steel strength (for a single anchor)	N _{sa}	lbf (kN)	4,495 (20.0)	8,230 (36.6)	13,110 (58.3)	19,400 (86.3)	26,780 (119.1)	35,130 (156.3)	56,210 (250.0)
		V _{sa}	lbf (kN)	2,695 (12.0)	4,940 (22.0)	7,860 (35.0)	11,640 (51.8)	16,070 (71.4)	21,080 (93.8)	33,725 (150.0)
	Reduction factor for seismic shear	α _{v,seis}	-	0.80	0.80	0.80	0.80	0.80	0.80	0.80
	Strength reduction factor for tension ²	φ	-	0.75						
Strength reduction factor for shear ²	φ	-	0.65							
ASTM F 1554 Grade 55	Nominal strength as governed by steel strength (for a single anchor)	N _{sa}	lbf (kN)	5,810 (25.9)	10,640 (47.3)	16,950 (75.4)	25,085 (111.6)	34,625 (154.0)	45,425 (202.0)	72,680 (323.3)
		V _{sa}	lbf (kN)	3,485 (15.5)	6,385 (28.4)	10,170 (45.2)	15,050 (67.0)	20,775 (92.4)	27,255 (121.2)	43,610 (194.0)
	Reduction factor for seismic shear	α _{v,seis}	-	0.80	0.80	0.80	0.80	0.80	0.80	0.80
	Strength reduction factor for tension ²	φ	-	0.75						
Strength reduction factor for shear ²	φ	-	0.65							
ASTM A 193 Grade B7 and ASTM F 1554 Grade 105	Nominal strength as governed by steel strength (for a single anchor)	N _{sa}	lbf (kN)	9,685 (43.1)	17,735 (78.9)	28,250 (125.7)	41,810 (186.0)	57,710 (256.7)	75,710 (336.8)	121,135 (538.8)
		V _{sa}	lbf (kN)	5,815 (25.9)	10,640 (47.3)	16,950 (75.4)	25,085 (111.6)	34,625 (154.0)	45,425 (202.1)	72,680 (323.3)
	Reduction factor for seismic shear	α _{v,seis}	-	0.80	0.80	0.80	0.80	0.80	0.80	0.80
	Strength reduction factor for tension ²	φ	-	0.75						
Strength reduction factor for shear ²	φ	-	0.65							
ASTM A 449	Nominal strength as governed by steel strength (for a single anchor)	N _{sa}	lbf (kN)	9,300 (41.4)	17,025 (75.7)	27,120 (120.6)	40,140 (178.5)	55,905 (248.7)	72,685 (323.3)	101,755 (452.6)
		V _{sa}	lbf (kN)	5,580 (24.8)	10,215 (45.4)	16,270 (72.4)	24,085 (107.1)	33,540 (149.2)	43,610 (194.0)	61,050 (271.6)
	Reduction factor for seismic shear	α _{v,seis}	-	0.80	0.80	0.80	0.80	0.80	0.80	0.80
	Strength reduction factor for tension ²	φ	-	0.75						
Strength reduction factor for shear ²	φ	-	0.65							
ISO 898-1 Class 5.8	Nominal strength as governed by steel strength (for a single anchor)	N _{sa}	lbf (kN)	5,620 (25.0)	10,290 (45.8)	16,385 (72.9)	24,250 (107.9)	33,475 (148.9)	43,915 (195.4)	- ⁵
		V _{sa}	lbf (kN)	3,370 (15.0)	6,175 (27.5)	9,830 (43.7)	14,550 (64.7)	20,085 (89.3)	26,350 (117.2)	- ⁵
	Reduction factor for seismic shear	α _{v,seis}	-	0.80	0.80	0.80	0.80	0.80	0.80	- ⁵
	Strength reduction factor for tension ³	φ	-	0.65						
Strength reduction factor for shear ³	φ	-	0.60							
ASTM F 593 CW Stainless (Types 304 and 316)	Nominal strength as governed by steel strength (for a single anchor)	N _{sa}	lbf (kN)	7,750 (34.5)	14,190 (63.1)	22,600 (100.5)	28,430 (126.5)	39,245 (174.6)	51,485 (229.0)	82,370 (366.4)
		V _{sa}	lbf (kN)	4,650 (20.7)	8,515 (37.9)	13,560 (60.3)	17,060 (75.9)	23,545 (104.7)	30,890 (137.4)	49,425 (219.8)
	Reduction factor for seismic shear	α _{v,seis}	-	0.70	0.70	0.80	0.80	0.80	0.80	0.80
	Strength reduction factor for tension ³	φ	-	0.65						
Strength reduction factor for shear ³	φ	-	0.60							
ASTM A 193 Grade B8/B8M, Class 1 Stainless (Types 304 and 316)	Nominal strength as governed by steel strength (for a single anchor) ⁴	N _{sa}	lbf (kN)	4,420 (19.7)	8,090 (36.0)	12,880 (57.3)	19,065 (84.8)	26,315 (117.1)	34,525 (153.6)	55,240 (245.7)
		V _{sa}	lbf (kN)	2,650 (11.8)	4,855 (21.6)	7,730 (34.4)	11,440 (50.9)	15,790 (70.2)	20,715 (92.1)	33,145 (147.4)
	Reduction factor for seismic shear	α _{v,seis}	-	0.70	0.70	0.80	0.80	0.80	0.80	0.80
	Strength reduction factor for tension ²	φ	-	0.75						
Strength reduction factor for shear ²	φ	-	0.65							
ASTM A 193 Grade B8/B8M2, Class 2B Stainless (Types 304 and 316)	Nominal strength as governed by steel strength (for a single anchor)	N _{sa}	lbf (kN)	7,365 (32.8)	13,480 (60.0)	21,470 (95.5)	31,775 (141.3)	43,860 (195.1)	57,545 (256.0)	92,065 (409.5)
		V _{sa}	lbf (kN)	4,420 (19.7)	8,085 (36.0)	12,880 (57.3)	19,065 (84.8)	26,315 (117.1)	34,525 (153.6)	55,240 (245.7)
	Reduction factor for seismic shear	α _{v,seis}	-	0.70	0.70	0.80	0.80	0.80	0.80	0.80
	Strength reduction factor for tension ²	φ	-	0.75						
Strength reduction factor for shear ²	φ	-	0.65							

For SI: 1 inch = 25.4 mm, 1 lbf = 4.448 N. For pound-inch units: 1 mm = 0.03937 inches, 1 N = 0.2248 lbf.

- Values provided for steel element material types are based on minimum specified strengths and calculated in accordance with ACI 318-14 Eq. 17.4.1.2 and Eq. 17.5.1.2b or ACI 318-11 Eq. (D-2) and Eq. (D-29), as applicable, except where noted. Nuts and washers must be appropriate for the rod. Nuts must have specified proof load stresses equal to or greater than the minimum tensile strength of the specified threaded rod.
- The tabulated value of φ applies when the load combinations of Section 1605.2 of the IBC, ACI 318-14 5.3 or ACI 318-11 9.2, as applicable, are used in accordance with ACI 318-14 17.3.3 or ACI 318-11 D.4.3, as applicable. If the load combinations of ACI 318-11 Appendix C are used, the appropriate value of φ must be determined in accordance with ACI 318 D.4.4. Values correspond to ductile steel elements.
- The tabulated value of φ applies when the load combinations of Section 1605.2 of the IBC, ACI 318-14 5.3 or ACI 318-11 9.2, as applicable, are used in accordance with ACI 318-14 17.3.3 or ACI 318-11 D.4.3, as applicable. If the load combinations of ACI 318-11 Appendix C are used, the appropriate value of φ must be determined in accordance with ACI 318 D.4.4. Values correspond to brittle steel elements.
- In accordance with AASHTO 318-14 17.4.1.2 and 17.5.1.2 or ACI 318-11 D.5.1.2 and D.6.1.2, as applicable, the calculated values for nominal tension and shear strength for ASTM A193 Grade B8/B8M Class 1 stainless steel threaded rods are based on limiting the specified tensile strength of the anchor steel to 1.9f_y or 57,000 psi (393 MPa).
- The referenced standard includes rod diameters up to and including 1-inch (24 mm).

Steel Tension and Shear Design for Reinforcing Bars in Normal Weight Concrete
(For use with load combinations taken from ACI 318-14 Section 5.3)

**CODE LIST-
ED**



Design Information			Symbol	Units	Nominal Reinforcing Bar Size (Rebar)									
					No. 3	No. 4	No. 5	No. 6	No. 7	No. 8	No. 9	No. 10		
Rebar nominal outside diameter			d	inch (mm)	0.375 (9.5)	0.500 (12.7)	0.625 (15.9)	0.750 (19.1)	0.875 (22.2)	1.000 (25.4)	1.125 (28.7)	1.250 (32.3)		
Rebar effective cross-sectional area			A _{se}	inch ² (mm ²)	0.110 (71.0)	0.200 (129.0)	0.310 (200.0)	0.440 (283.9)	0.600 (387.1)	0.790 (509.7)	1.000 (645.2)	1.270 (819.4)		
ASTM A 615 Grade 75	Nominal strength as governed by steel strength (for a single anchor)		N _{sa}	lbf (kN)	11,000 (48.9)	20,000 (89.0)	31,000 (137.9)	44,000 (195.7)	60,000 (266.9)	79,000 (351.4)	100,000 (444.8)	127,000 (564.9)		
			V _{sa}	lbf (kN)	6,600 (29.4)	12,000 (53.4)	18,600 (82.7)	26,400 (117.4)	36,000 (160.1)	47,400 (210.8)	60,000 (266.9)	76,200 (338.9)		
	Reduction factor for seismic shear		α _{v,seis}	-	0.70	0.70	0.80	0.80	0.80	0.80	0.80	0.80		
	Strength reduction factor for tension ³		φ	-	0.65									
	Strength reduction factor for shear ³		φ	-	0.60									
ASTM A 615 Grade 60	Nominal strength as governed by steel strength (for a single anchor)		N _{sa}	lbf (kN)	9,900 (44.0)	18,000 (80.1)	27,900 (124.1)	39,600 (176.1)	54,000 (240.2)	71,100 (316.3)	90,000 (400.3)	114,300 (508.4)		
			V _{sa}	lbf (kN)	5,940 (26.4)	10,800 (48.0)	16,740 (74.5)	23,760 (105.7)	32,400 (144.1)	42,660 (189.8)	54,000 (240.2)	68,580 (305.0)		
	Reduction factor for seismic shear		α _{v,seis}	-	0.70	0.70	0.80	0.80	0.80	0.80	0.80	0.80		
	Strength reduction factor for tension ²		φ	-	0.75									
	Strength reduction factor for shear ²		φ	-	0.65									
ASTM A 706 Grade 60	Nominal strength as governed by steel strength (for a single anchor)		N _{sa}	lbf (kN)	8,800 (39.1)	16,000 (71.2)	24,800 (110.3)	35,200 (156.6)	48,000 (213.5)	63,200 (281.1)	80,000 (355.9)	101,600 (452.0)		
			V _{sa}	lbf (kN)	5,280 (23.5)	9,600 (42.7)	14,880 (66.2)	21,120 (94.0)	28,800 (128.1)	37,920 (168.7)	48,000 (213.5)	60,960 (271.2)		
	Reduction factor for seismic shear		α _{v,seis}	-	0.70	0.70	0.80	0.80	0.80	0.80	0.80	0.80		
	Strength reduction factor for tension ²		φ	-	0.75									
	Strength reduction factor for shear ²		φ	-	0.65									
ASTM A 615 Grade 40	Nominal strength as governed by steel strength (for a single anchor)		N _{sa}	lbf (kN)	6,600 (29.4)	12,000 (53.4)	18,600 (82.7)	26,400 (117.4)	In accordance with ASTM A 615, Grade 40 bars are furnished only in sizes No. 3 through No. 6					
			V _{sa}	lbf (kN)	3,960 (17.6)	7,200 (32.0)	11,160 (49.6)	15,840 (70.5)						
	Reduction factor for seismic shear		α _{v,seis}	-	0.70	0.70	0.80	0.80						
	Strength reduction factor for tension ²		φ	-	0.75									
	Strength reduction factor for shear ²		φ	-	0.65									

For SI: 1 inch = 25.4 mm, 1 lbf = 4.448 N. For pound-inch units: 1 mm = 0.03937 inches, 1 N = 0.2248 lbf.

- Values provided for reinforcing bar material types based on minimum specified strengths and calculated in accordance with ACI 318-14 Eq. 17.4.1.2 and Eq. 17.5.1.2b or ACI 318-11 Eq. (D-2) and Eq. (D-29), as applicable.
- The tabulated value of φ applies when the load combinations of Section 1605.2 of the IBC, ACI 318-14 5.3 or ACI 318-11 9.2, as applicable, are used in accordance with ACI 318-14 17.3.3 or ACI 318-11 D.4.3, as applicable. If the load combinations of ACI 318-11 Appendix C are used, the appropriate value of φ must be determined in accordance with ACI 318 D.4.4. Values correspond to ductile steel elements. In accordance with ACI 318-14 17.2.3.4.3(a)(vi) or ACI 318-11 D.3.3.4.3(a)6, as applicable, deformed reinforcing bars meeting this specification used as ductile steel elements to resist earthquake effects shall be limited to reinforcing bars satisfying the requirements of ACI 318-14 20.2.2.4 and 20.2.2.5 or ACI 318-11 21.1.5.2 (a) and (b), as applicable.
- The tabulated value of φ applies when the load combinations of Section 1605.2 of the IBC, ACI 318-14 5.3 or ACI 318-11 9.2, as applicable, are used in accordance with ACI 318-14 17.3.3 or ACI 318-11 D.4.3, as applicable. If the load combinations of ACI 318-11 Appendix C are used, the appropriate value of φ must be determined in accordance with ACI 318 D.4.4. Values correspond to brittle steel elements.

ADHESIVES

PURE110+
Epoxy Injection Adhesive Anchoring System

Concrete Breakout Design Information for Threaded Rod and Reinforcing Bars
 (For use with loads combinations taken from ACI 318-14 Section 5.3)¹

CODE LIST-ED



Design Information	Symbol	Units	Nominal Rod Diameter (inch) / Reinforcing Bar Size							
			3/8 or #3	1/2 or #4	5/8 or #5	3/4 or #6	7/8 or #7	1 or #8	#9	1-1/4 or #10
Effectiveness factor for cracked concrete	$k_{c,cr}$	- (SI)	17 (7.1)							
Effectiveness factor for uncracked concrete	$k_{c,uncr}$	- (SI)	24 (10.0)							
Minimum embedment	$h_{ef,min}$	inch (mm)	2-3/8 (60)	2-3/4 (70)	3-1/8 (79)	3-1/2 (89)	3-1/2 (89)	4 (102)	4-1/2 (114)	5 (127)
Maximum embedment	$h_{ef,max}$	inch (mm)	7-1/2 (191)	10 (254)	12-1/2 (318)	15 (381)	17-1/2 (445)	20 (508)	22-1/2 (572)	25 (635)
Minimum anchor spacing	s_{min}	inch (mm)	1-7/8 (48)	2-1/2 (64)	3-1/8 (79)	3-3/4 (95)	4-3/8 (111)	5 (127)	5-5/8 (143)	6-1/4 (159)
Minimum edge distance ²	c_{min}	inch (mm)	5d where d is nominal outside diameter of the anchor							
Minimum edge distance, reduced ²	$c_{min,red}$	inch (mm)	1-3/4 (45)	1-3/4 (45)	1-3/4 (45)	1-3/4 (45)	1-3/4 (45)	1-3/4 (45)	2-3/4 (70)	2-3/4 (70)
Minimum member thickness	h_{min}	inch (mm)	$h_{ef} + 1-1/4 (h_{ef} + 30)$		$h_{ef} + 2d_o$ where d_o is hole diameter;					
Critical edge distance—splitting (for uncracked concrete only) ³	c_{ac}	inch	$c_{ac} = h_{ef} \cdot \left(\frac{\tau_{k,uncr}}{1160}\right)^{0.4} \cdot [3.1 - 0.7 \frac{h}{h_{ef}}]$							
		(mm)	$c_{ac} = h_{ef} \cdot \left(\frac{\tau_{k,uncr}}{8}\right)^{0.4} \cdot [3.1 - 0.7 \frac{h}{h_{ef}}]$							
Strength reduction factor for tension, concrete failure modes, Condition B ⁴	ϕ	-	0.65							
Strength reduction factor for shear, concrete failure modes, Condition B ⁴	ϕ	-	0.70							

For SI: 1 inch = 25.4 mm, 1 lbf = 4.448 N. For pound-inch units: 1 mm = 0.03937 inch, 1 N = 0.2248 lbf.

- Additional setting information is described in the installation instructions.
- For installation between the minimum edge distance, c_{min} , and the reduced minimum edge distance, $c_{min,red}$, the maximum torque applied must be reduced (multiplied) by a factor of 0.45.
- $\tau_{k,uncr}$ need not be taken as greater than: $\tau_{k,uncr} = \frac{k_{uncr} \cdot \sqrt{h_{ef} \cdot f'_c}}{\pi \cdot d}$ and $\frac{h}{h_{ef}}$ need not be taken as larger than 2.4.
- Condition A requires supplemental reinforcement, while Condition B applies where supplemental reinforcement is not provided or where pryout governs, as set forth in ACI 318-14 17.3.3 or ACI 318-11 D.4.3, as applicable. The tabulated value of ϕ applies when the load combinations of Section 1605.2 of the IBC, ACI 318-14 5.3 or ACI 318-11 9.2, as applicable, are used in accordance with ACI 318-14 17.3.3 or ACI 318-11 D.4.3, as applicable. If the load combinations of ACI 318-11 Appendix C are used, the appropriate value of ϕ must be determined in accordance with ACI 318 D.4.4.

FLOWCHART FOR THE ESTABLISHMENT OF DESIGN BOND STRENGTH

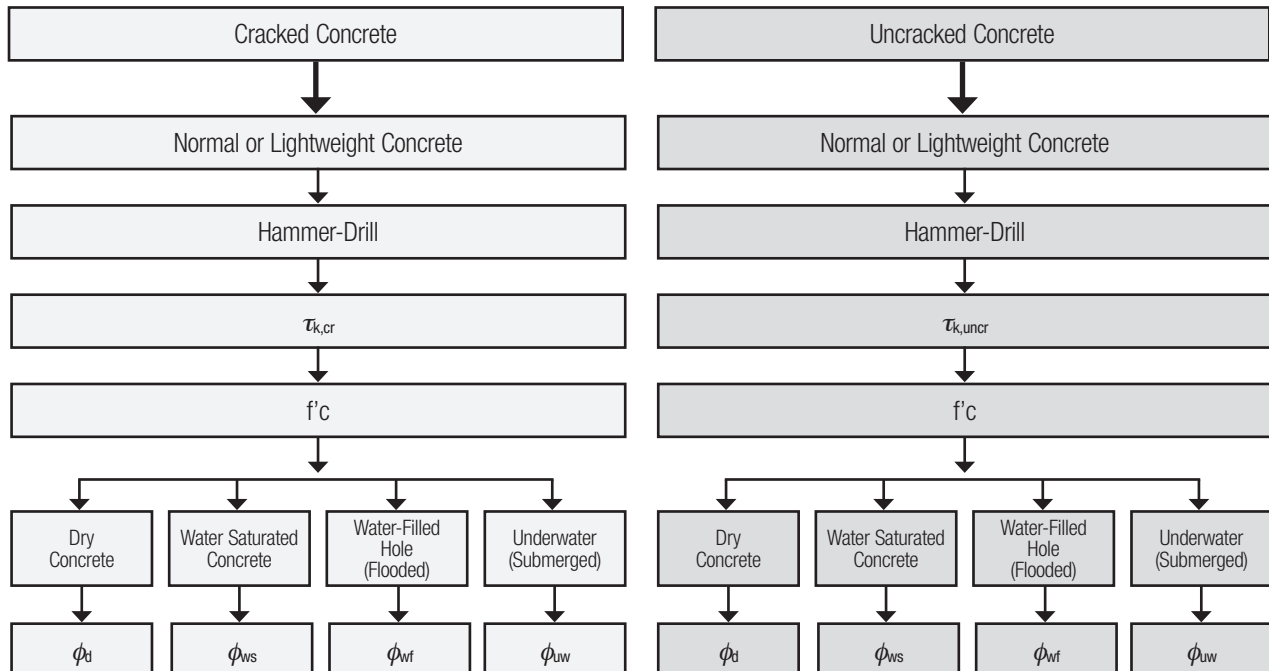

Bond Strength Design Information for Threaded Rods and Reinforcing Bars
 (For use with load combinations taken from ACI 318-14 Section 5.3)^{1,2}

**CODE LIST-
ED**



Design Information	Symbol	Units	Nominal Rod Diameter (inch) / Reinforcing Bar Size							
			3/8 or #3	1/2 or #4	5/8 or #5	3/4 or #6	7/8 or #7	1 or #8	#9	1 1/4 or #10
Minimum embedment	$h_{ef,min}$	inch (mm)	2-3/8 (60)	2-3/4 (70)	3-1/8 (79)	3-1/2 (89)	3-1/2 (89)	4 (102)	4-1/2 (114)	5 (127)
Maximum embedment	$h_{ef,max}$	inch (mm)	7-1/2 (191)	10 (254)	12-1/2 (318)	15 (381)	17-1/2 (445)	20 (508)	22-1/2 (572)	25 (635)
110°F (43°C) Maximum Long-Term Service Temperature; 140°F (60°C) Maximum Short-Term Service Temperature ^{3,5}	Characteristic bond strength in cracked concrete ^{6,9}	$\tau_{k,cr}$ psi (N/mm ²)	990 (6.8)	990 (6.8)	959 (6.6)	959 (6.6)	959 (6.6)	918 (6.3)	846 (5.8)	846 (5.8)
	Characteristic bond strength in uncracked concrete ^{6,8}	$\tau_{k,uncr}$ psi (N/mm ²)	1,756 (12.1)	1,668 (11.5)	1,604 (11.1)	1,553 (10.7)	1,512 (10.4)	1,477 (10.2)	1,446 (10.0)	1,420 (9.8)
110°F (43°C) Maximum Long-Term Service Temperature; 176°F (80°C) Maximum Short-Term Service Temperature ^{4,5}	Characteristic bond strength in cracked concrete ^{6,9}	$\tau_{k,cr}$ psi (N/mm ²)	725 (5.0)	725 (5.0)	696 (4.8)	696 (4.8)	696 (4.8)	667 (4.6)	624 (4.3)	624 (4.3)
	Characteristic bond strength in uncracked concrete ^{6,8}	$\tau_{k,uncr}$ psi (N/mm ²)	1,276 (8.8)	1,218 (8.4)	1,175 (8.1)	1,131 (7.6)	1,102 (7.6)	1,073 (7.4)	1,059 (7.3)	1,030 (7.1)
Permissible Installation Conditions ⁷	Dry concrete	Anchor Category	-	1						
		ϕ_d	-	0.65						
	Water-saturated concrete, Water-filled hole (flooded)	Anchor Category	-	2						
		ϕ_{ws}, ϕ_{wf}	-	0.55						
	Underwater (submerged)	Anchor Category	-	2			3			
		ϕ_{uw}	-	0.55			0.45			
Reduction factor for seismic tension ⁹		$C_{D1,seis}$	-	1						

For SI: 1 inch = 25.4 mm, 1 psi = 0.006894 MPa. For pound-inch units: 1 mm = 0.03937 inch, 1 MPa = 145.0 psi.

- Bond strength values correspond to a normal-weight concrete compressive strength $f'_c = 2,500$ psi (17.2 MPa). For concrete compressive strength, f'_c between 2,500 psi and 8,000 psi (17.2 MPa and 55.2 MPa), the tabulated characteristic bond strength may be increased by a factor of $(f'_c / 2,500)^{0.25}$ [For SI: $(f'_c / 17.2)^{0.25}$].
- The modification factor for bond strength of adhesive anchors in lightweight concrete shall be taken as given in ACI 318 17.2.6, where applicable.
- The maximum short-term service temperature may be increased to 162°F (72°C) provided characteristic bond strengths are reduced by 3 percent. Long-term and short-term temperatures meet the requirements of Section 8.5 of ACI 355.4 and Table 8.1, Temperature Category B.
- Long-term and short-term temperatures meet the requirements of Section 8.5 of ACI 355.4 and Table 8.1, Temperature Category A.
- Short-term base material service temperatures are those that occur over brief intervals, e.g. as a result of diurnal cycling. Long-term base material service temperatures are roughly constant over significant periods of time.
- Characteristic bond strengths are for sustained loads including dead and live loads.
- Permissible installation conditions include dry concrete, water-saturated concrete, water-filled holes and underwater. Water-filled holes include applications in dry or water-saturated concrete where the drilled holes contain standing water at the time of anchor installation.
- Bond strength values for uncracked concrete are applicable for structures assigned to Seismic Design Categories A and B only.
- For structures assigned to Seismic Design Categories C, D, E or F, the tabulated bond strength values for cracked concrete do not require an additional reduction factor applied for seismic tension ($C_{D1,seis} = 1.0$), where seismic design is applicable.

ADHESIVES

PURE110+[®]
Epoxy Injection Adhesive Anchoring System



Tension and Shear Design Strength Installed in Uncracked Concrete (Bond or Concrete Strength)

Drilled with a Hammer-Drill and Carbide Bit in a Dry Hole Condition

110°F (43°C) Maximum Long-Term Service Temperature;

140°F (60°C) Maximum Short-Term Service Temperature^{1,2,3,4,5,6,7,8,9}

Nominal Rod/Rebar Size (in. or #)	Embed. Depth h_{ef} (in.)	Minimum Concrete Compressive Strength									
		$f'c = 2,500$ (psi)		$f'c = 3,000$ (psi)		$f'c = 4,000$ (psi)		$f'c = 6,000$ (psi)		$f'c = 8,000$ (psi)	
		ϕN_{cb} or ϕN_{cp} Tension (lbs.)	ϕN_{cb} or ϕN_{cp} Shear (lbs.)	ϕN_{cb} or ϕN_{cp} Tension (lbs.)	ϕN_{cb} or ϕN_{cp} Shear (lbs.)	ϕN_{cb} or ϕN_{cp} Tension (lbs.)	ϕN_{cb} or ϕN_{cp} Shear (lbs.)	ϕN_{cb} or ϕN_{cp} Tension (lbs.)	ϕN_{cb} or ϕN_{cp} Shear (lbs.)	ϕN_{cb} or ϕN_{cp} Tension (lbs.)	ϕN_{cb} or ϕN_{cp} Shear (lbs.)
3/8 or #3	2-3/8	2,855	2,570	3,125	2,920	3,560	3,555	3,905	4,205	4,175	4,495
	3	4,035	4,000	4,205	4,455	4,495	5,285	4,935	6,720	5,270	7,965
	4-1/2	6,050	7,305	6,310	8,135	6,740	9,645	7,400	12,260	7,905	14,540
	7-1/2	10,085	15,545	10,515	17,315	11,235	20,530	12,335	26,100	13,180	28,385
1/2 or #4	2-3/4	3,555	3,305	3,895	3,755	4,500	4,590	5,510	6,095	6,120	7,340
	4	6,240	6,700	6,835	7,610	7,590	9,165	8,330	11,650	8,900	13,815
	6	10,220	12,640	10,655	14,080	11,385	16,695	12,500	21,225	13,355	25,165
	10	17,030	26,920	17,760	29,990	18,975	35,560	20,830	44,865	22,255	47,930
5/8 or #5	3-1/8	4,310	4,120	4,720	4,680	5,450	5,720	6,675	7,600	7,710	9,295
	5	8,720	9,985	9,555	11,345	11,030	13,875	12,520	17,875	13,375	21,195
	7-1/2	15,355	19,390	16,010	21,600	17,105	25,610	18,780	32,560	20,065	38,605
	12-1/2	25,590	41,320	26,685	46,030	28,510	54,580	31,295	67,410	33,440	72,020
3/4 or #6	3-1/2	5,105	5,015	5,595	5,700	6,460	6,970	7,910	9,255	9,135	11,320
	6	11,465	13,595	12,560	15,445	14,500	18,895	17,455	24,920	18,650	29,550
	9	21,060	26,855	22,325	30,115	23,850	35,705	26,180	45,390	27,970	53,820
	15	35,675	57,590	37,205	64,155	39,750	76,065	43,635	93,985	46,620	100,410
7/8 or #7	3-1/2	5,105	4,930	5,595	5,605	6,460	6,855	7,910	9,100	9,135	11,130
	7	14,445	16,605	15,825	18,865	18,275	23,075	22,380	30,650	24,710	36,825
	10-1/2	26,540	32,800	29,070	37,265	31,605	44,495	34,695	56,565	37,070	67,065
	17-1/2	47,280	71,775	49,305	79,955	52,675	94,800	57,825	120,520	61,780	133,065
1 or #8	4	6,240	6,115	6,835	6,945	7,895	8,495	9,665	11,280	11,160	13,800
	8	17,650	19,750	19,335	22,435	22,325	27,440	27,340	36,450	31,530	44,555
	12	32,425	39,005	35,520	44,315	40,325	53,835	44,265	68,440	47,295	81,150
	20	60,320	86,850	62,905	96,750	67,210	114,715	73,775	145,835	78,825	169,775
#9	4-1/2	7,445	7,110	8,155	8,080	9,420	9,880	11,535	13,125	13,320	16,055
	9	21,060	23,055	23,070	26,190	26,640	32,035	32,625	42,550	37,675	52,040
	13-1/2	38,690	45,540	42,380	51,740	48,940	63,280	54,850	81,120	58,600	96,185
	22-1/2	74,740	102,905	77,945	114,635	83,275	135,920	91,415	172,790	97,670	204,875
1-1/4	5	8,720	8,170	9,555	9,285	11,030	11,355	13,510	15,085	15,600	18,450
	10	24,665	26,380	27,020	29,975	31,200	36,660	38,210	48,690	44,125	59,555
	15	45,315	52,110	49,640	59,200	57,320	72,410	66,495	94,110	71,045	111,585
	25	90,615	119,440	94,495	133,050	100,960	157,755	110,830	200,555	118,410	237,790
#10	5	8,720	8,160	9,555	9,270	11,030	11,335	13,510	15,060	15,600	18,420
	10	24,665	26,430	27,020	30,025	31,200	36,725	38,210	48,780	44,125	59,660
	15	45,315	52,205	49,640	59,310	57,320	72,545	66,495	94,285	71,045	111,790
	25	90,615	119,615	94,495	133,245	100,960	157,985	110,830	200,850	118,410	238,140

■ - Concrete Breakout Strength ■ - Bond Strength/Pryout Strength

- Tabular values are provided for illustration and are applicable for single anchors installed in uncracked normal-weight concrete with minimum slab thickness, $h_a = h_{min}$, and with the following conditions:
 - c_{a1} is greater than or equal to the critical edge distance, c_{ac}
 - c_{a2} is greater than or equal to 1.5 times c_{a1} .
- Calculations were performed according to ACI 318-14 Ch.17 and ICC-ES AC308. The load level corresponding to the failure mode listed [Concrete breakout strength, bond strength/pryout strength] must be checked against the tabulated steel strength of the corresponding threaded rod or rebar size and type, the lowest load level controls.
- Strength reduction factors (ϕ) for concrete breakout strength are based on ACI 318-14 Section 5.3 for load combinations. Condition B was assumed.
- Strength reduction factors (ϕ) for bond strength are determined from reliability testing and qualification in accordance with ICC-ES AC308 and are tabulated in this product information and in ESR-3298.
- Tabular values are permitted for static loads only, seismic loading is not considered with these tables. Periodic special inspection must be performed where required by code, see ESR-3298 for applicable information.
- For anchors subjected to tension resulting from sustained loading a supplemental check must be performed according to ACI 318-14 17.3.1.2.
- For designs that include combined tension and shear, the interaction of tension and shear loads must be calculated in accordance with ACI 318-14 Ch.17.
- Interpolation is not permitted to be used with the tabular values. For intermediate base material compressive strengths, please see ACI 318-14 Ch.17, ICC-ES AC308 and information included in this product supplement. For other design conditions including seismic considerations please see ACI 318-14 Ch.17 and ICC-ES AC308 and ESR-3298.
- Long term concrete temperatures are roughly constant over significant periods of time. Short-term elevated temperatures are those that occur over brief intervals, e.g. as a result of diurnal cycling.

ADHESIVES

PURE110+®

Epoxy Injection Adhesive Anchoring System



**Tension and Shear Design Strength Installed in Cracked Concrete
(Bond or Concrete Strength)
Drilled with a Hammer-Drill and Carbide Bit in a Dry Hole Condition
110°F (43°C) Maximum Long-Term Service Temperature;
140°F (60°C) Maximum Short-Term Service Temperature^{1,2,3,4,5,6,7,8,9}**

Nominal Rod/Rebar Size (in. or #)	Embed. Depth h_{ef} (in.)	Minimum Concrete Compressive Strength										
		$f'_c = 2,500$ (psi)		$f'_c = 3,000$ (psi)		$f'_c = 4,000$ (psi)		$f'_c = 6,000$ (psi)		$f'_c = 8,000$ (psi)		
		ϕN_{cb} or ϕN_s Tension (lbs.)	ϕN_{cb} or ϕN_{cp} Shear (lbs.)	ϕN_{cb} or ϕN_s Tension (lbs.)	ϕN_{cb} or ϕN_{cp} Shear (lbs.)	ϕN_{cb} or ϕN_s Tension (lbs.)	ϕN_{cb} or ϕN_{cp} Shear (lbs.)	ϕN_{cb} or ϕN_s Tension (lbs.)	ϕN_{cb} or ϕN_{cp} Shear (lbs.)	ϕN_{cb} or ϕN_s Tension (lbs.)	ϕN_{cb} or ϕN_{cp} Shear (lbs.)	
3/8 or #3	2-3/8	1,800	1,835	1,880	2,020	2,005	2,160	2,200	2,370	2,355	2,535	
	3	2,275	2,860	2,370	3,185	2,535	3,775	2,780	4,800	2,970	5,690	
	4-1/2	3,410	5,215	3,560	5,810	3,800	6,890	4,170	8,760	4,460	9,600	
	7-1/2	5,685	11,100	5,930	12,370	6,335	13,645	6,955	14,980	7,430	16,005	
1/2 or #4	2-3/4	2,520	2,360	2,760	2,680	3,095	3,280	3,400	4,355	3,630	5,245	
	4	4,045	4,785	4,215	5,435	4,505	6,545	4,945	8,320	5,285	9,870	
	6	6,065	9,030	6,325	10,060	6,755	11,925	7,420	15,160	7,925	17,070	
5/8 or #5	10	10,110	19,230	10,540	21,420	11,260	24,255	12,365	26,630	13,210	28,450	
	3-1/8	3,050	2,940	3,345	3,340	3,850	4,085	4,335	5,430	4,720	6,640	
	5	6,120	7,135	6,380	8,105	6,820	9,910	7,485	12,770	7,995	15,140	
	7-1/2	9,180	13,850	9,575	15,430	10,230	18,295	11,225	23,255	11,995	25,835	
3/4 or #6	12-1/2	15,300	29,515	15,955	32,880	17,045	36,715	18,710	40,305	19,990	43,060	
	3-1/2	3,620	3,580	3,965	4,070	4,575	4,980	5,325	6,610	5,790	8,085	
	6	8,120	9,710	8,895	11,035	9,820	13,495	10,780	17,800	11,515	21,105	
	9	13,220	19,185	13,785	21,510	14,730	25,505	16,165	32,420	17,275	37,205	
7/8 or #7	15	22,030	41,135	22,975	45,825	24,545	52,870	26,945	58,035	28,790	62,005	
	3-1/2	3,620	3,525	3,965	4,000	4,575	4,895	5,360	6,500	5,810	7,950	
	7	10,230	11,860	11,210	13,475	12,945	16,485	14,670	21,895	15,675	26,300	
	10-1/2	17,990	23,430	18,765	26,620	20,045	31,780	22,005	40,405	23,510	47,905	
1 or #8	17-1/2	29,985	51,270	31,270	57,110	33,410	67,715	36,675	78,995	39,185	84,395	
	4	4,420	4,365	4,840	4,960	5,590	6,065	6,655	8,060	7,215	9,855	
	8	12,500	14,105	13,695	16,025	15,815	19,600	18,340	26,035	19,595	31,825	
	12	22,495	27,860	23,460	31,655	25,065	38,455	27,515	48,885	29,395	57,965	
#9	20	37,490	62,035	39,095	69,110	41,770	81,940	45,855	98,765	48,990	105,520	
	4-1/2	5,275	5,080	5,780	5,770	6,670	7,060	7,620	9,375	8,260	11,465	
	9	14,920	16,465	16,340	18,710	18,870	22,880	21,395	30,390	22,855	37,170	
	13-1/2	26,235	32,530	27,360	36,955	29,235	45,200	32,090	57,945	34,285	68,700	
1-1/4	22-1/2	43,730	73,505	45,600	81,880	48,720	97,085	53,485	115,195	57,140	123,075	
	5	6,175	5,835	6,765	6,630	7,815	8,110	9,465	10,775	10,260	13,175	
	10	17,470	18,845	19,140	21,410	22,100	26,185	26,410	34,780	28,220	42,540	
	15	32,095	37,220	33,780	42,285	36,090	51,720	39,615	67,225	42,325	79,705	
#10	25	53,985	85,315	56,300	95,035	60,150	112,685	66,030	142,215	70,545	151,945	
	5	6,175	5,830	6,765	6,620	7,815	8,100	9,365	10,755	10,150	13,155	
	10	17,470	18,880	19,140	21,445	22,100	26,230	26,410	34,840	28,220	42,615	
	15	32,095	37,290	33,780	42,365	36,090	51,815	39,615	67,345	42,325	79,850	
		25	53,985	85,440	56,300	95,175	60,150	112,850	66,030	142,215	70,545	151,945

■ - Concrete Breakout Strength ■ - Bond Strength/Pryout Strength

- Tabular values are provided for illustration and are applicable for single anchors installed in cracked normal-weight concrete with minimum slab thickness, $h_a = h_{min}$, and with the following conditions:
 - C_{a1} is greater than or equal to the critical edge distance, C_{ae}
 - C_{a2} is greater than or equal to 1.5 times C_{a1} .
- Calculations were performed according to ACI 318-14 Ch.17 and ICC-ES AC308. The load level corresponding to the failure mode listed [Concrete breakout strength, bond strength/pryout strength] must be checked against the tabulated steel strength of the corresponding threaded rod or rebar size and type, the lowest load level controls.
- Strength reduction factors (ϕ) for concrete breakout strength are based on ACI 318-14 Section 5.3 for load combinations. Condition B was assumed.
- Strength reduction factors (ϕ) for bond strength are determined from reliability testing and qualification in accordance with ICC-ES AC308 and are tabulated in this product information and in ESR-3298.
- Tabular values are permitted for static loads only, seismic loading is not considered with these tables. Periodic special inspection must be performed where required by code, see ESR-3298 for applicable information.
- For anchors subjected to tension resulting from sustained loading a supplemental check must be performed according to ACI 318-14 17.3.1.2.
- For designs that include combined tension and shear, the interaction of tension and shear loads must be calculated in accordance with ACI 318-14 Ch.17.
- Interpolation is not permitted to be used with the tabular values. For intermediate base material compressive strengths, please see ACI 318-14 Ch.17, ICC-ES AC308 and information included in this product supplement. For other design conditions including seismic considerations please see ACI 318-14 Ch.17 and ICC-ES AC308 and ESR-3298.
- Long term concrete temperatures are roughly constant over significant periods of time. Short-term elevated temperatures are those that occur over brief intervals, e.g. as a result of diurnal cycling.

ADHESIVES

PURE110+[®]
Epoxy Injection Adhesive Anchoring System



ADHESIVES

Tension Design of Steel Elements (Steel Strength)^{1,2}

Steel Elements - Threaded Rod and Reinforcing Bar												
Nominal Rod/Rebar Size (in. or No.)	ASTM A36 and ASTM F1554 Grade 36	ASTM F1554 Grade 55	ASTM A193 Grade B7 and ASTM F1554 Grade 105	ASTM A449	ASTM F568M Class 5.8 and ISO 898-1 Class 5.8	ASTM F593 CW Stainless (Types 304 and 316)	ASTM A193 Grade B8/B8M, Class 1 Stainless (Types 304 and 316)	ASTM A193 Grade B8/B8M2, Class 2B Stainless (Types 304 and 316)	ASTM A615 Grade 75 Rebar	ASTM A615 Grade 60 Rebar	ASTM A706 Grade 60 Rebar	ASTM A615 Grade 40 Rebar
	ϕN_{ts} Tension (lbs.)	ϕN_{ts} Tension (lbs.)	ϕN_{ts} Tension (lbs.)	ϕN_{ts} Tension (lbs.)	ϕN_{ts} Tension (lbs.)	ϕN_{ts} Tension (lbs.)	ϕN_{ts} Tension (lbs.)	ϕN_{ts} Tension (lbs.)	ϕN_{ts} Tension (lbs.)	ϕN_{ts} Tension (lbs.)	ϕN_{ts} Tension (lbs.)	ϕN_{ts} Tension (lbs.)
3/8 or #3	3,370	4,360	7,265	6,975	3,655	5,040	3,315	5,525	7,150	7,425	6,600	4,950
1/2 or #4	6,175	7,980	13,300	12,770	6,690	9,225	6,070	10,110	13,000	13,500	12,000	9,000
5/8 or #5	9,835	12,715	21,190	20,340	10,650	14,690	9,660	16,105	20,150	20,925	18,600	13,950
3/4 or #6	14,550	18,815	31,360	30,105	15,765	18,480	14,300	23,830	28,600	29,700	26,400	19,800
7/8 or #7	20,085	25,970	43,285	41,930	21,760	25,510	19,735	32,895	39,000	40,500	36,000	-
1 or #8	26,350	34,070	56,785	54,515	28,545	33,465	25,895	43,160	51,350	53,325	47,400	-
#9	-	-	-	-	-	-	-	-	65,000	67,500	60,000	-
1-1/4 or #10	42,160	54,510	9,100	76,315	-	53,540	41,430	69,050	82,550	85,725	76,200	-

■ - Steel Strength

1. Steel tensile design strength according to ACI 318-14 Ch.17, $\phi N_{ts} = \phi \cdot A_{se,N} \cdot f_{uts}$
 2. The tabulated steel design strength in tension must be checked against the bond strength/concrete capacity design strength to determine the controlling failure mode, the lowest load level controls.

Shear Design of Steel Elements (Steel Strength)^{1,2}

Steel Elements - Threaded Rod and Reinforcing Bar												
Nominal Rod/Rebar Size (in. or No.)	ASTM A36 and ASTM F1554 Grade 36	ASTM F1554 Grade 55	ASTM A193 Grade B7 and ASTM F1554 Grade 105	ASTM A449	ASTM F568M Class 5.8 and ISO 898-1 Class 5.8	ASTM F593 CW Stainless (Types 304 and 316)	ASTM A193 Grade B8/B8M, Class 1 Stainless (Types 304 and 316)	ASTM A193 Grade B8/B8M2, Class 2B Stainless (Types 304 and 316)	ASTM A615 Grade 75 Rebar	ASTM A615 Grade 60 Rebar	ASTM A706 Grade 60 Rebar	ASTM A615 Grade 40 Rebar
	ϕV_{sa} Shear (lbs.)	ϕV_{sa} Shear (lbs.)	ϕV_{sa} Shear (lbs.)	ϕV_{sa} Shear (lbs.)	ϕV_{sa} Shear (lbs.)	ϕV_{sa} Shear (lbs.)	ϕV_{sa} Shear (lbs.)	ϕV_{sa} Shear (lbs.)	ϕV_{sa} Shear (lbs.)	ϕV_{sa} Shear (lbs.)	ϕV_{sa} Shear (lbs.)	ϕV_{sa} Shear (lbs.)
3/8 or #3	1,755	2,265	3,775	3,625	2,025	2,790	1,725	2,870	3,960	3,860	3,430	2,575
1/2 or #4	3,210	4,150	6,915	6,640	3,705	5,110	3,155	5,255	7,200	7,020	6,240	4,680
5/8 or #5	5,115	6,610	11,020	10,575	5,900	8,135	5,025	8,375	11,160	10,880	9,670	7,255
3/4 or #6	7,565	9,785	16,305	15,655	8,730	10,235	7,435	12,390	15,840	15,445	13,730	10,295
7/8 or #7	10,445	13,505	22,505	21,805	12,050	14,130	10,265	17,105	21,600	21,060	18,720	-
1 or #8	13,700	17,715	29,525	28,345	15,810	18,535	13,465	22,445	28,440	27,730	24,650	-
#9	-	-	-	-	-	-	-	-	36,000	35,100	31,200	-
1-1/4 or #10	21,920	28,345	4,735	39,685	-	29,655	21,545	35,905	45,720	44,575	39,625	-

■ - Steel Strength

1. Steel shear design strength according to ACI 318-14 Ch.17, $\phi V_{sa} = \phi \cdot 0.60 \cdot A_{se,V} \cdot f_{uts}$
 2. The tabulated steel design strength in shear must be checked against the bond strength/concrete capacity design strength to determine the controlling failure mode, the lowest load level controls.

PURE110+[®]
Epoxy Injection Adhesive Anchoring System

INSTALLATION INSTRUCTIONS (SOLID BASE MATERIALS)

PERMISSIBLE INSTALLATION CONDITIONS (ADHESIVE)

Dry Concrete: cured concrete that, at the time of adhesive anchor installation, has not been exposed to water for the preceding 14 days.

Water-Saturated Concrete (wet): cured concrete that, at the time of adhesive anchor installation, has been exposed to water over a sufficient length of time to have the maximum possible amount of absorbed water into the concrete pore structure to a depth equal to the anchor embedment depth.

Water-Filled Holes (flooded): cured concrete that is water-saturated and where the drilled hole contains standing water at the time of anchor installation.

Underwater Concrete (submerged): cured concrete that is water-saturated and covered with water at the time of anchor installation.

DRILLING

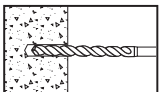

1- Drill a hole into the base material with a rotary hammer drill tool to the size and embedment required by the selected steel anchor element (reference installation specifications for threaded rod and reinforcing bar). The tolerances of the carbide drill bit must meet ANSI Standard B212.15.

- Precaution: Use suitable eye and skin protection. Avoid inhalation of dust during drilling and/or removal.
- **Note!** In case of standing water in the drilled hole (flooded hole condition), all the water has to be removed from the hole (e.g. vacuum, compressed air, etc.) prior to cleaning. For underwater (submerged) installations please see separated specific instructions below.

HOLE CLEANING DRY OR WET/WATER-SATURATED HOLES (BLOW 2X, BRUSH 2X, BLOW 2X)



2a- Starting from the bottom or back of the drilled anchor hole, blow the hole clean (free of noticeable dust) a minimum of two times (2x).

- Use a compressed air nozzle (min. 90 psi) for all sizes of anchor rod and reinforcing bar (rebar).

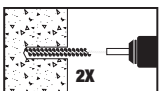

2b- Determine wire brush diameter (see installation specifications) hole cleaning equipment selection table) for the drilled hole and attach the brush with adaptor to a rotary drill tool or battery screw gun. Brush the hole with the selected wire brush a minimum of two times (2x). A brush extension (supplied by DeWALT) must be used for holes drilled deeper than the listed brush length.

- The wire brush diameter must be checked periodically during use. The brush should resist insertion into the drilled hole, if it does not come into contact with the sides of the drilled hole, the brush is too small and must be replaced.

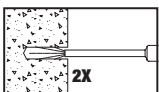

2c- Repeat Step 2a- again by blowing the hole clean a minimum of two times (2x).

- When finished the hole should be clean and free of dust, debris, ice, grease, oil or other foreign material.

NEXT GO TO STEP 3.

HOLE CLEANING UNDERWATER INSTALLATION (FLUSH, BRUSH 2X, FLUSH)

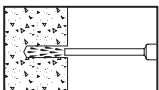

2a- Starting from the bottom or back of the drilled anchor hole, rinse/flush the hole clean with air/water (air/water line pressure) until clear water comes out.

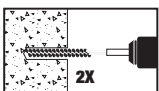

2b- Determine brush diameter (see installation specifications) for the drilled hole and attach the brush with adaptor to a rotary drill tool. Brush the hole with the selected wire brush a minimum of two times (2x). A brush extension (supplied by DeWALT) must be used for holes drilled deeper than the listed brush length.

- The wire brush diameter must be checked periodically during use. The brush should resist insertion into the drilled hole, if it does not come into contact with the sides of the drilled hole, the brush is too small and must be replaced.

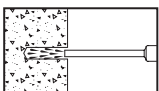

2c- Repeat Step 2a- again by rinse/flushing the hole clean with air/water.

- When finished the hole should be clean and free of dust, debris, ice, grease, oil or other foreign material.

NEXT GO TO STEP 3.

PREPARING



3- Check adhesive expiration date on cartridge label. Do not use expired product. Review Safety Data Sheet (SDS) before use. Cartridge temperature must be between 50°F - 104°F (10°C - 40°C) when in use; for overhead applications cartridge temperature must be between 50°F - 90°F (10°C - 30°C). Review published working and cure times. Consideration should be given to the reduced gel (working) time of the adhesive in warm temperatures. For permitted range of the base material temperature, see published gel and curing times.

- Attach a supplied mixing nozzle to the cartridge. Do not modify the mixer in any way and make sure the mixing element is inside the nozzle. Load the cartridge into the correct dispensing tool.
- Note: Always use a new mixing nozzle with new cartridge of adhesive and also for all work interruptions exceeding the published gel (working) time of the adhesive.

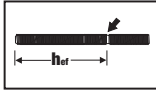

4- Prior to inserting the anchor rod or rebar into the filled bore hole, the position of the embedment depth has to be marked on the anchor. Verify anchor element is straight and free of surface damage.

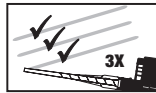

5- Adhesives must be properly mixed to achieve published properties. Prior to dispensing adhesive into the drilled hole, separately dispense at least three full strokes of adhesive through the mixing nozzle until the adhesive is a consistent **RED** color.

- Review and note the published working and cure times (reference gel time and curing time table) prior to injection of the mixed adhesive into the cleaned anchor hole.

INSTALLATION

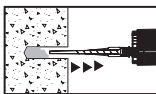

6- Fill the cleaned hole approximately two-thirds full with mixed adhesive starting from the bottom or back of the anchor hole. Slowly withdraw the mixing nozzle as the hole fills to avoid creating air pockets or voids. For embedment depth greater than 8 inches an extension nozzle must be used with the mixing nozzle.

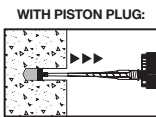

WITH PISTON PLUG:

• Piston plugs (see installation specifications) must be used with and attached to the mixing nozzle and extension tube for horizontal installations where embedment is greater than 8 inches and overhead installations in concrete with anchor rod from 1/2" to 1-1/4" diameter and rebar sizes #4 to #10. Insert piston plug to the back of the drilled hole and inject as described in the method above. During installation the piston plug will be naturally extruded from the drilled hole by the adhesive pressure.

- **Attention!** Do not install anchors overhead without proper training and installation hardware provided by the DeWALT. Contact DeWALT for details prior to use.

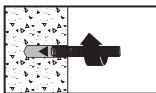

7- The anchor should be free of dirt, grease, oil or other foreign material. Push clean threaded rod or reinforcing bar into the anchor hole while turning slightly to ensure positive distribution of the adhesive until the embedment depth is reached. Observe the gel (working) time.

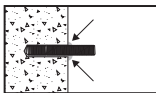

8- Ensure that the anchor element is installed to the specific embedment depth. Adhesive must completely fill the annular gap at the concrete surface. Following installation of the anchor element, remove excess adhesive. Protect the anchor element threads from fouling with adhesive. For all installations the anchor element must be fully restrained from movement throughout the specified curing period, where necessary through the use of temporary wedges, external supports, or other methods. Minor adjustment to the position of the anchor element may be performed during the gel time only.

CURING AND LOADING

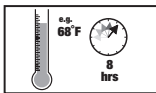

9- Allow the adhesive anchor to cure to the specified full curing time prior to applying any load (reference gel time and curing time table).

- Do not disturb, torque or load the anchor until it is fully cured.



10- After full curing of the adhesive anchor, a fixture can be installed to the anchor and tightened up to the maximum torque (reference gel time and curing table) by using a calibrated torque wrench.

- Take care not to exceed the maximum torque for the selected anchor.

INSTALLATION INSTRUCTIONS (HOLLOW BASE MATERIALS)

DRILLING

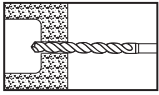

1- Drill a hole into the base material with a rotary drill tool to the size and embedment for the required screen size (see installation specifications for threaded rod in hollow concrete base material with screen tube supplied by DeWALT). The tolerances of the drill bit used should meet the requirements of ANSI B212.15.

- Precaution: Wear suitable eye and skin protection. Avoid inhalation of dust during drilling and/or removal.

HOLE CLEANING (BLOW 2X, BRUSH 2X, BLOW 2X)

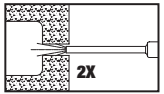

2- Starting from the bottom or back of the anchor hole, blow the hole clean with a hand pump (min. volume 25 fl.oz. supplied by DeWALT) or compressed air nozzle a minimum of two times (2x).

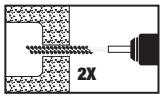

- Determine the wire brush diameter (see installation specifications) and attach the brush with adaptor to a rotary drill tool or battery screw gun. Brush the hole with the selected wire brush a minimum of two times (2x). A brush extension (supplied by DeWALT, Cat #08282) should be used for holes drilled deeper than the listed brush length.

- The wire brush should be checked periodically during use. The brush must be replaced if it becomes worn and does not come in contact with sides of the drill hole.

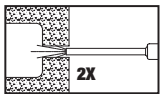

- Finally, blow the hole clean again a minimum of two times (2x)

- When finished the hole should be clean and free of dust, debris, ice, grease, oil or other foreign material.

PREPARING



3- Check adhesive expiration date on cartridge label. Do not use expired product. Review Safety Data Sheet (SDS) before use. Cartridge temperature must be between 50°F - 104°F (10°C - 40°C) when in use. Review gel (working) time and curing time table. Consideration should be given to the reduced gel (working) time of the adhesive in warm temperatures.

- Attach a supplied mixing nozzle to the cartridge. Do not modify the mixer in any way and make sure the mixing element is inside the nozzle. Load the cartridge into the correct dispensing tool.

- Note: Always use a new mixing nozzle with new cartridges of adhesive and also for all work interruptions exceeding the published working time of the adhesive.

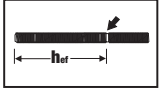

4- Prior to inserting the anchor rod into the filled screen tube, the position of the embedment depth has to be marked on the anchor. Verify anchor element is straight and free of surface damage.

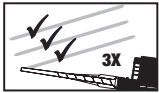

5- Adhesive must be properly mixed to achieve published properties. Prior to dispensing adhesive into the drilled hole, separately dispense at least three full strokes of adhesive through the mixing nozzle until the adhesive is a consistent RED color. Do not attach a used nozzle when changing to a new cartridge.

- Review and note the published working and cure times (see gel time and curing time table) prior to injection of the mixed adhesive into the screen tube.

INSTALLATION

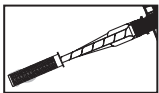

6- Select a screen tube of suitable length (supplied by DeWALT). Fill the screen tube full with adhesive starting from the bottom or back of the tube. Slowly withdraw the mixing nozzle as the screen fills to avoid creating air pockets or voids. A plastic extension tube supplied by DeWALT must be used with the mixing nozzle if the back of the screen tube cannot be reached.

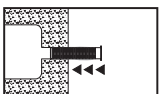

7- Insert the screen tube filled with adhesive into the cleaned anchor hole.

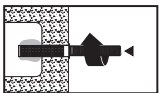

8- Prior to inserting the anchor rod into the screen tube inspect it to ensure that it is free of dirt, grease, oil or other foreign material.

- Push the threaded rod into the screen tube while turning slightly to ensure positive distribution of the adhesive until back of the tube is reached.

CURING AND FIXTURE

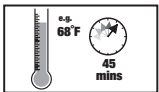

9- Allow the adhesive anchor to cure to the specified full curing time prior to applying any load.

- Do not disturb, torque or load the anchor until it is fully cured (see gel time and curing time table).

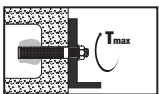

10- After full curing of the adhesive anchor, a fixture can be installed to the anchor and tightened up to the maximum torque (see installation specifications for threaded rod and reinforcing bar in hollow base material) by using a calibrated torque wrench.

- Take care not to exceed the maximum torque for the selected anchor.

REFERENCE INSTALLATION TABLES

Gel (working) Time and Curing Table

Temperature of base material		Gel (working) time	Full curing time
°F	°C		
41	5	120 minutes	48 hours
50	10	90 minutes	24 hours
68	20	25 minutes	8 hours
86	30	20 minutes	8 hours
95	35	15 minutes	6 hours
104	40	12 minutes	4 hours

Linear interpolation for intermediate base material temperature is possible.

For installations in base material temperatures between 41°F and 50°F (5°C and 10°C) the cartridge temperature must be conditioned to 68°F (20°C).

Hole Cleaning Equipment Selection Table for Pure110+

Rod Diameter (inch)	Rebar Size (No.)	ANSI Drill Bit Diameter (inch)	Min. Brush Diameter, D _{min} (inches)	Brush Length, L (inches)	Steel Wire Brush ^{2,3} (Cat. #)	Blowout Tool	Number of cleaning actions
Solid Base Material							
3/8	#3	7/16	0.475	6-3/4	08284	Compressed air nozzle only, Cat #8292 (min. 90 psi)	2x blowing 2x brushing 2x blowing
1/2	-	9/16	0.600	6-3/4	08285		
-	#4	5/8	0.670	6-3/4	08275		
5/8	#5	11/16	0.735	7-7/8	08286		
		3/4	0.790	7-7/8	08278		
3/4	#6	7/8	0.920	7-7/8	08287		
7/8	#7	1	1.045	11-7/8	08288		
1	#8	1-1/8	1.175	11-7/8	08289		
1-1/4	#9	1-3/8	1.425	11-7/8	08290		
-	#10	1-1/2	1.550	11-7/8	08291		
Hollow Base Material (with plastic screen tube)							
3/8	-	9/16	0.735	6-3/4	08285	Compressed air nozzle only, Cat #8292 (min. 90 psi)	2x blowing 2x brushing 2x blowing
1/2	-	3/4	0.780	7-7/8	08278		
5/8	-	7/8	0.920	7-7/8	08287		
3/4	-	1	1.045	11-7/8	08288		

1. For installations with 5/8-inch threaded rod and #5 rebar size, the preferred ANSI drill bit diameter is 3/4-inch. If an 11/16-inch ANSI drill bit is used the user must check before injecting the adhesive to verify that the steel anchor element can be inserted into the cleaned borehole without resistance.

2. An SDS-plus adaptor (Cat. #08283) or Jacobs chuck style adaptor (Cat. #08296) is required to attach a steel wire brush to the drill tool.

3. A brush extension (Cat. #08282) must be used with a steel wire brush for holes drilled deeper than the listed brush length.

Adhesive Piston Plugs^{1,2,3,4}

Rod Diameter (inch)	Rebar Size (No.)	ANSI Drill Bit Diameter (inch)	Plug Size (inch)	Plastic Plug (Cat. #)	Piston Plug
Solid Base Materials					
1/2	-	9/16	9/16	08302	
-	#4	5/8	5/8	08304	
5/8	#5	11/16	11/16	08258	
		3/4	3/4	08259	
3/4	#6	7/8	7/8	08300	
7/8	#7	1	1	08301	
1	#8	1-1/8	1-1/8	08303	
1-1/4	#9	1-3/8	1-3/8	08305	
-	#10	1-1/2	1-1/2	08309	

1. All overhead installations require the use of piston plugs where one is tabulated together with the anchor size.

2. All horizontal installations require the use of piston plugs where one is tabulated together with the anchor size and where the embedment depth is greater than 8 inches.

3. The use of piston plugs is also recommended for underwater installations where one is tabulated together with the anchor size.

4. A flexible plastic extension tube (cat# 08297) or equivalent approved by DeWALT must be used with piston plugs.

ORDERING INFORMATION

Pure110+ Cartridges

Cat. No.	Description	Std. Box	Std. Ctn.	Pallet
08310SD	Pure110+ 9 fl. oz. Quik-Shot cartridge (1:1 mix ratio)	12	24	432
08321SD	Pure110+ 21 fl. oz. dual cartridge (1:1 mix ratio)	12	-	540
08313SD	Pure110+ 13 fl. oz. dual cartridge (3:1 mix ratio)	12	-	540
08320SD	Pure110+ 20 fl. oz. dual cartridge (3:1 mix ratio)	12	-	540

One Pure110+ mixing nozzle is packaged with each cartridge.

Pure110+ mixing nozzles must be used to ensure complete and proper mixing of the adhesive.



Cartridge System Mixing Nozzles

Cat. No.	Description	Std. Pkg.	Std. Ctn.
08294	Extra mixing nozzle (with 8" extension) for Pure110+ Quik-Shot	2	24
08281	Mixing nozzle extension, 8" long	2	24
08297	Mixing nozzle extension, 20" long	1	12
08609	Extra high flow mixing nozzle (with 8" extension) for Pure110+ dual cartridge	2	24



Dispensing Tools for Injection Adhesive

Cat. No.	Description	Std. Box	Std. Ctn.
08437	Manual caulking gun for Quik-Shot	1	12
08479	High performance caulking gun for Quik-Shot	1	12
08409	21 fl. oz. Standard metal manual tool	1	10
08421	21 fl. oz. High performance manual tool	1	10
DCE591D1	21 fl. oz. 20v Battery powered dispensing tool	1	-
08413	21 fl. oz. Pneumatic tool	1	-
08298	13 fl. oz. + 20 fl. oz. Manual tool (3:1 mix ratio)	1	6
DCE593D1	13 fl. oz. + 20 fl. oz. 20v Battery powered dispensing tool (3:1 mix ratio)	1	-
08497SD	13 fl. oz. + 20 fl. oz. Pneumatic tool (3:1 mix ratio)	1	6



Hole Cleaning Tools and Accessories

Cat. No.	Description	Std. Box
08284	Wire brush for 7/16" ANSI hole (3/8" rod or #3 rebar), 6-3/4" length	1
08285	Wire brush for 9/16" ANSI hole (1/2" rod or #4 rebar), 6-3/4" length	1
08275	Wire brush for 5/8" ANSI hole (#4 rebar), 6-3/4" length	1
08286	Wire brush for 11/16" ANSI hole (5/8" rod or #5 rebar), 7-7/8" length	1
08278	Wire brush for 3/4" ANSI hole (5/8" rod or #5 rebar), 7-7/8" length	1
08287	Wire brush for 7/8" ANSI hole (3/4" rod or #6 rebar), 7-7/8" length	1
08288	Wire brush for 1" ANSI hole (7/8" rod or #7 rebar), 11-7/8" length	1
08289	Wire brush for 1-1/8" ANSI hole (1" rod or #8 rebar), 11-7/8" length	1
08290	Wire brush for 1-3/8" ANSI hole (1-1/4" rod or #9 rebar), 11-7/8" length	1
08291	Wire brush for 1-1/2" ANSI hole (#10 rebar), 11-7/8" length	1
08283	SDS-plus adapter for steel brushes	1
08296	Standard drill adapter for steel brushes (e.g. Jacobs Chuck)	1
08282	Steel brush extension, 12" length	1
08292	Air compressor nozzle with extension, 18" length	1

Adhesive Piston Plugs

Cat. #	Description	ANSI Drill Bit Dia.	Threaded Rod Dia.	Reinforcing Bar Size	Std. Bag ¹
08302	9/16" Plug	9/16"	1/2"	#4	10
08304	5/8" Plug	5/8"	-	#4	10
08258	11/16" Plug	11/16"	5/8"	#5	10
08259	3/4" Plug	3/4"	5/8"	#5	10
08300	7/8" Plug	7/8"	3/4"	#6	10
08301	1" Plug	1"	7/8"	#7	10
08303	1-1/8" Plug	1-1/8"	1"	#8	10
08305	1-3/8" Plug	1-3/8"	1-1/4"	#9	10
08309	1-1/2" Plug	1-1/2"	-	#10	10

Plastic Screen Tubes

Cat.No.	Description	ANSI Drill Diameter	Standard Carton
08310	3/8" x 3-1/2" Plastic Screen	9/16"	25
08311	3/8" x 6" Plastic Screen	9/16"	25
08313	3/8" x 8" Plastic Screen	9/16"	25
08315	1/2" x 3-1/2" Plastic Screen	3/4"	25
08317	1/2" x 6" Plastic Screen	3/4"	25
08321	5/8" x 6" Plastic Screen	7/8"	25
08323	3/4" x 6" Plastic Screen	1"	10

For availability of stainless steel screen tubes, Contact DeWALT