

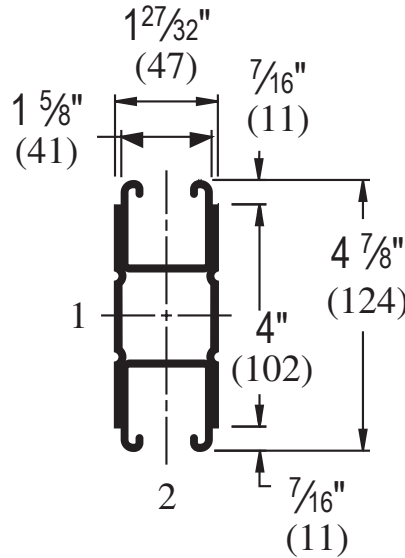

**P1004 A**

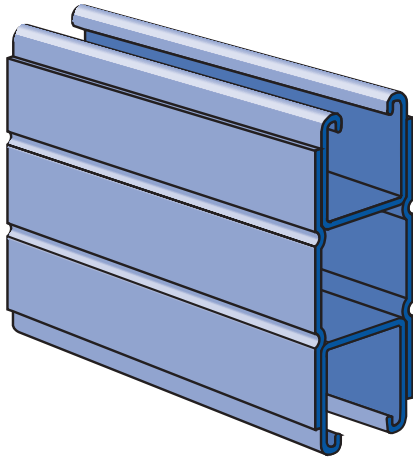

\*Load limited by spot weld shear.

\*\*  $KL/r > 200$

**Notes:**

1. Above loads include the weight of the member. This weight must be deducted to arrive at the net allowable load the beam will support.
2. Long span beams should be supported in such a manner as to prevent rotation and twist.
3. Allowable uniformly distributed loads are listed for various simple spans, that is, a beam on two supports. If load is concentrated at the center of the span, multiply load from the table by 0.5 and corresponding deflection by 0.8.

Wt/100 Ft: 668 Lbs (994 kg/100 m)  
 Allowable Moment 41,970 In-Lbs (4,740 N•m)  
 12 Gauge Nominal Thickness .105" (2.7mm)

**MATERIAL**

Unistrut channels are accurately and carefully cold formed to size from low-carbon strip steel. All spot-welded combination members, except P1001T, are welded 3" (76 mm) maximum on center.

**STEEL: PLAIN**

12 Ga. (2.7 mm), 14 Ga.(1.9 mm) and  
 16 Ga. (1.5 mm) ASTM A1011 SS GR 33.

**STEEL: PRE-GALVANIZED**

12 Ga. (2.7 mm), 14 Ga. (1.9 mm) and  
 16 Ga. (1.5mm) ASTM A653 GR 33.

For other materials, see Special Metals or Fiberglass sections.

**FINISHES**

All channels are available in:

- Perma Green III (GR).
- Pre-galvanized (PG), conforming to ASTM A653 G90.
- Hot-dipped galvanized (HG), conforming to ASTM A123.
- Plain (PL).

<p><b>Project:</b> _____</p> <p><b>Architect / Engineer:</b> _____</p> <p><b>Date:</b> _____ <b>Phone:</b> _____</p> <p><b>Contractor:</b> _____</p> <p><b>Address:</b> _____</p> <p>_____</p> <p><b>Notes 1:</b> _____</p> <p>_____</p> <p><b>Notes 2:</b> _____</p> <p>_____</p>	<p><b>Approval Stamp:</b></p>
------------------------------------------------------------------------------------------------------------------------------------------------------------------------------------------------------------------------------------------------------------------------------------	-------------------------------