

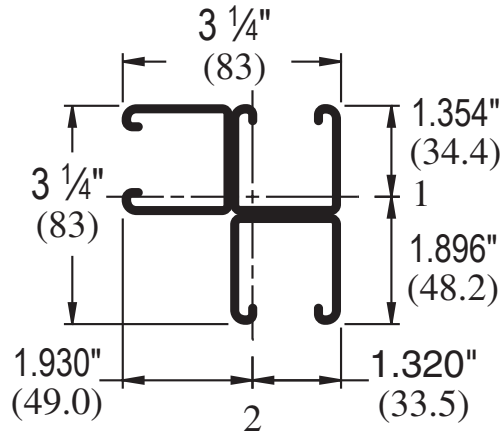

**P1001 C3**

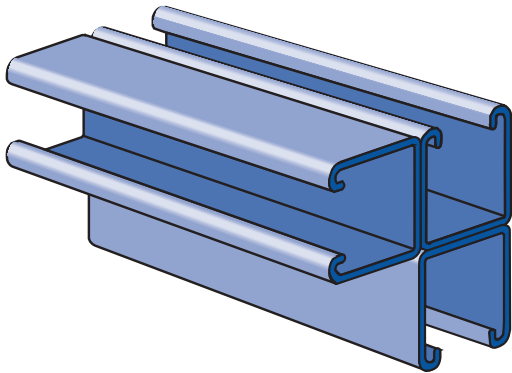

Wt/100 Ft: 566 Lbs (843 kg/100 m)  
 Allowable Moment 18,680 In-Lbs (2,110 N•m)  
 12 Gauge Nominal Thickness .105" (2.7mm)

**MATERIAL**

Unistrut channels are accurately and carefully cold formed to size from low-carbon strip steel. All spot-welded combination members, except P1001T, are welded 3" (76 mm) maximum on center.

**STEEL: PLAIN**

12 Ga. (2.7 mm), 14 Ga.(1.9 mm) and  
 16 Ga. (1.5 mm) ASTM A1011 SS GR 33.

**STEEL: PRE-GALVANIZED**

12 Ga. (2.7 mm), 14 Ga. (1.9 mm) and  
 16 Ga. (1.5mm) ASTM A653 GR 33.

For other materials, see Special Metals or Fiberglass sections.

**FINISHES**

All channels are available in:

- Perma Green III (GR).
- Pre-galvanized (PG), conforming to ASTM A653 G90.
- Hot-dipped galvanized (HG), conforming to ASTM A123.
- Plain (PL).

<p><b>Project:</b> _____</p> <p><b>Architect / Engineer:</b> _____</p> <p><b>Date:</b> _____ <b>Phone:</b> _____</p> <p><b>Contractor:</b> _____</p> <p><b>Address:</b> _____</p> <p>_____</p> <p><b>Notes 1:</b> _____</p> <p>_____</p> <p><b>Notes 2:</b> _____</p> <p>_____</p>	<p><b>Approval Stamp:</b></p>
--	-------------------------------