

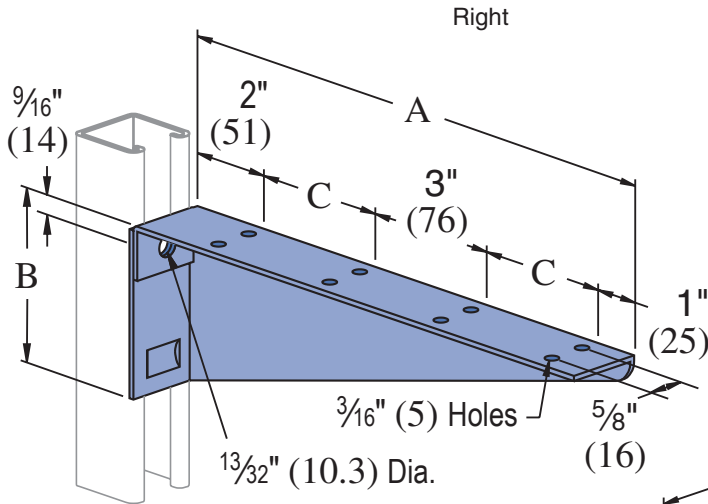

**A2494 R-L THRU A2497 R-L**



Part Number	A In (mm)	B In (mm)	C In (mm)	Wt/100 pcs Lbs (kg)
A2494 R-L	12 305	3 1/2 89	3 76	94 42.6
A2495 R-L	14 356	4 102	4 102	105 47.6
A2496 R-L	16 406	4 1/2 114	5 127	145 65.8
A2497 R-L	18 457	5 127	6 152	175 79.4

Material: 14 Gauge Steel.

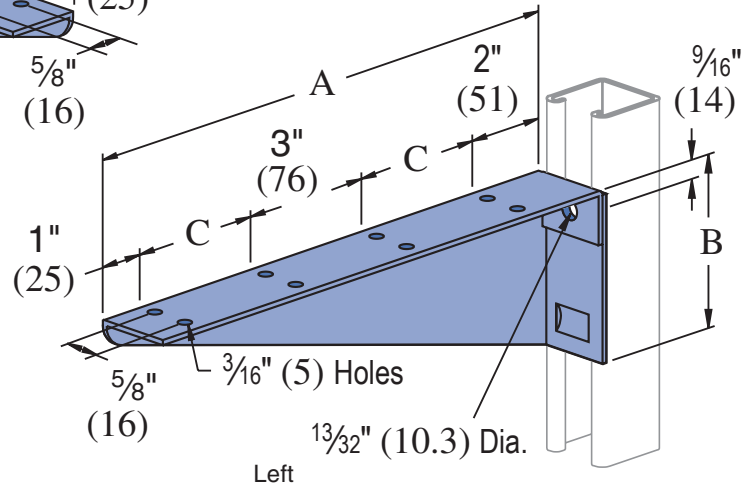

Design Uniform Load  
(Channel Upright Listed)

**A1000** 200 Lbs (.89 kN)  
**A4000** 130 Lbs (.58 kN)

Safety Factor of 2 1/2

**Standard Dimensions for 1 1/4" (32 mm) width series channel fittings (Unless Otherwise Shown on Drawing)**

Hole Diameter: 3/16" (10mm); Hole Spacing - From End: 5/8" (16 mm); Hole Spacing - On Center: 1 1/2" (38 mm); Width: 1 1/4" (32mm); Thickness: 3/16" (5mm)

**MATERIAL**

Unistrut channels are accurately and carefully cold formed to size from low-carbon strip steel.

**STEEL: PLAIN**

- 14 Gauge (1.9 mm), ASTM A1011 SS GR 33
- 19 Gauge (1.0 mm) ASTM A1008

**STEEL: PRE-GALVANIZED**

- 14 Gauge (1.9 mm) ASTM A653 GR 33,
- 19 Gauge (1.0 mm) ASTM A653 GR 33

Channel nuts are manufactured from mild steel bars conforming to ASTM A576, GR 1015, and are case hardened.

Fittings are made from hot rolled, pickled and oiled steel plate or strip and conform to ASTM A1011 SS GR 33.

Many framing channels are available in special metal on request. Consult factory for ordering information.

**FINISHES**

All channels and fittings are available in: Perma-Green III (GR), Pre-galvanized (PG), conforming to ASTM A653 GR 33 and plain (PL).

Nuts are available in plain or electro-galvanized (EG) finish.

Fittings are available in Perma-Green III (GR) or plain (PL).

**Project:** \_\_\_\_\_

**Architect / Engineer:** \_\_\_\_\_

**Date:** \_\_\_\_\_ **Phone:** \_\_\_\_\_

**Contractor:** \_\_\_\_\_

**Address:** \_\_\_\_\_

\_\_\_\_\_

**Notes 1:** \_\_\_\_\_

\_\_\_\_\_

**Notes 2:** \_\_\_\_\_

\_\_\_\_\_

**Approval Stamp:**