



The right way to attach almost anything to metal roofs!

Installation Instructions

S-5!® Warning! Please use these products responsibly! Visit our website or contact your S-5! distributor for available load test results.

IMPORTANT NOTICE to S-5! users: Due to the many variables involved with specific panel products and job particulars, -the manufacturer cannot and does not express any opinions as to the suitability of any S-5! assembly for any specific application and assumes no liability with respect thereto.

S-5! products are tested for ultimate holding strength on various profile types, materials, and brands of manufacture. This information is available from the S-5! website: www.S-5.com. This document is an installation guide only and the photographs and drawings herein are for the purpose of illustrating installation, tools and techniques, not system designs. Information contained within is intended to apply to the document as a whole.

The S-5-N and S-5-N Mini are designed to fit numerous (but dimensionally specific) 1" nail strip profiles. These profile types are vast with new variations coming into the market regularly. These clamps may not be suitable for every such profile. To avoid potential damage to roof seam it is important to verify clamp-to-roof suitability prior to installation. Consult the S-5! load table for suitability.

Tools Needed

- Screw Gun*
- 3/16" Allen Bit Tip (provided)
- Dial-Calibrated Torque Wrench
(For accurate tension values, do NOT use a clicking torque wrench).

To Install S-5-N and S-5-N Mini

1. Load the setscrew(s) into the clamp. **(Fig 1)**
2. Position clamp and insert at desired location along the seam as shown. **(Figs 2,3)**

NOTE: On some panel profiles it may be necessary to place the clamp onto the seam first and then slide the insert into it.

Components

0.80" Round Point Setscrew



S-5-N Clamp or S-5-N Mini Clamp



S-5-N Insert or S-5-N Mini Insert

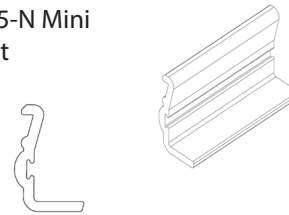

1.

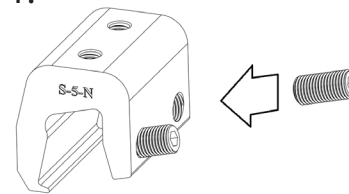

2.

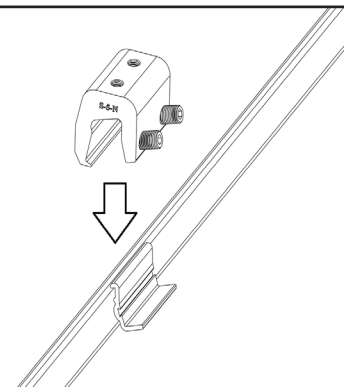

S-5-N and S-5-N Mini Installation Instructions

- The clamp should be over the seam and insert as shown. **(Fig 3a)** Make sure the toe of the clamp engages the female part of the seam as shown. **(Fig 3b)**
- Tighten the setscrew(s) using a screw gun* and the included bit tip **(Fig 4)**. When relying on published load values, setscrew tension should be verified periodically using a dial-indicating calibrated torque wrench to ensure the tool is consistently achieving the recommended torque range **(Table 1)**.

Only if installing the Standard-sized Clamp:

- Setscrews should be tensioned and re-tensioned as the seam material compresses, (i.e. tighten the first setscrew, then the second; then repeat).

When installing the Mini-sized clamp:

- The seam material will compress evenly the first tightening.

*** For time-saving tool recommendations, call S-5!**

Specified Torque	Inch Pounds	Foot Pounds	Nm
22ga steel	160-180	13-15	18-20
24ga steel and all other metals	130-150	11-12.5	15-17

Table 1

Note: Seams that exceed maximum allowance of 0.82" at the widest part of the seam may require hand crimping to facilitate clamp fit. **(Fig 5)**

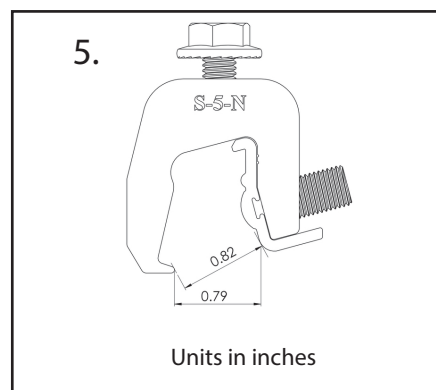
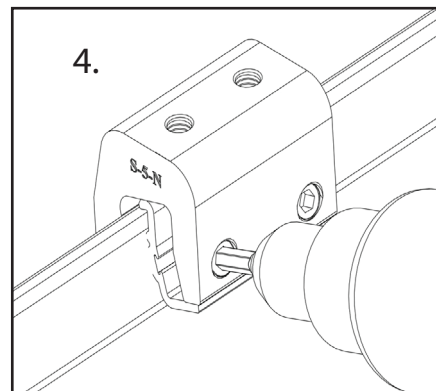
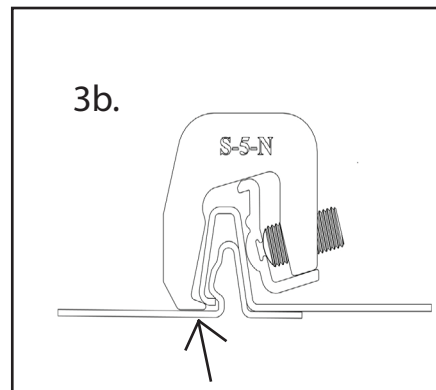
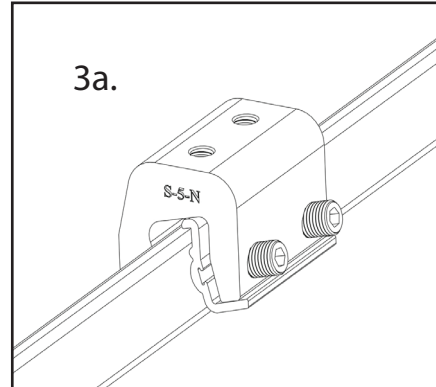

S-5!® Warning! Please use this product responsibly!

Products are protected by multiple U.S. and foreign patents. For published data regarding holding strength, fastener torque, patents, and trademarks, visit the S-5! website at www.S-5.com.
 Copyright 2018, Metal Roof Innovations, Ltd. S-5! products are patent protected. S-5! aggressively protects its patents, trademarks, and copyrights.
 NNmini-V1.0-0119