

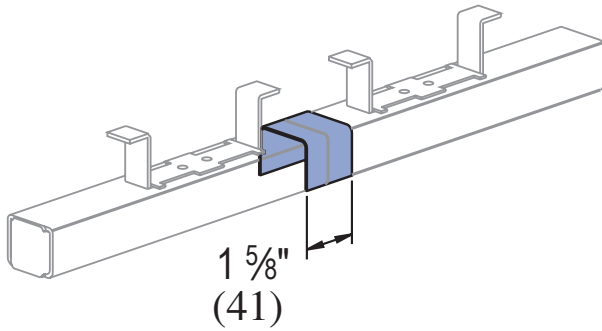

P3663, P4663

JOINT COVERS



Part Number	Use With Insert Series	Wt/100 pcs Lbs (kg)
P3663	P3270	10 4.5
P4663	P3370	6 2.7

NOTE: Joint cover for use with 1 5/8" wide standard Unistrut inserts only.

Note

When used for mechanical supports, load capacities of brackets and fittings should be in compliance with the American Standard Code for Pressure Piping.

MATERIAL

Cold-formed inserts are manufactured from standard 12 gauge (2.7 mm) Unistrut channel sections conforming to ASTM A1011 SS GR 33 or ASTM A653 GR 33, unless otherwise noted. Hot-rolled inserts, as noted, are manufactured from carbon steel meeting physical requirements of ASTM A283 GR D. To inhibit concrete seepage, all inserts (except spot inserts) are provided with closure strips and end caps or foam filler, unless otherwise requested. Most concrete inserts are available in stainless steel on special order. Consult factory for ordering information.

FINISHES

Cold-formed, standard-duty, light-duty and spot concrete inserts are available in:

- Perma-Green III (GR),
- Hot dipped galvanized (HG), conforming to ASTM A123 or A153;
- Pre-galvanized (PG), conforming to ASTM A653 GR 33
- Plain (PL).

Project: _____

Approval Stamp:

Architect / Engineer: _____

Date: _____ Phone: _____

Contractor: _____

Address: _____

Notes 1: _____

Notes 2: _____