

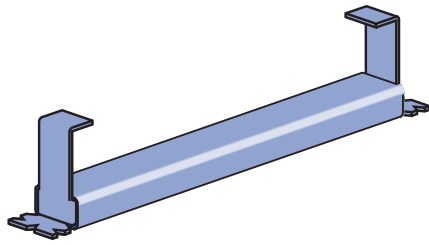

P3300 SERIES

1 5/8" x 7/8" CHANNEL

P3349 thru P3351



"NC" Suffix – No Closure Strip, With End Caps
 "WC" Suffix – With Closure Strip & End Caps



(When used for
 sprinkler systems only.)

P3352 thru P3353

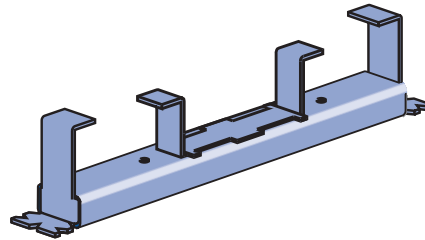

"NC" Suffix – No Closure Strip, With End Caps & Back Plates
 "WC" Suffix – With Closure Strip, End Caps & Back Plates

P3354 thru P3370

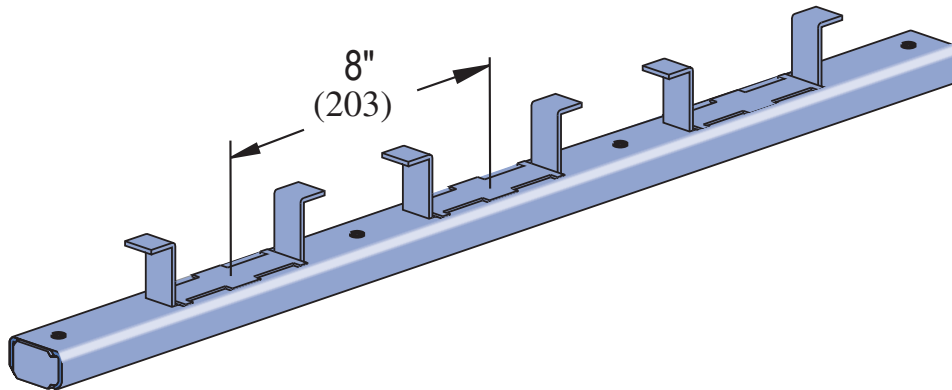

"NC" Suffix – No Closure Strip, W/End Caps & Back Plates
 "WC" Suffix – W/Closure Strip, End Caps & Back Plates
 "X" – No Closure Strip, No End Caps, W/Back Plates

MATERIAL

Cold-formed inserts are manufactured from standard 12 gauge (2.7 mm) Unistrut channel sections conforming to ASTM A1011 SS GR 33 or ASTM A653 GR 33, unless otherwise noted. Hot-rolled inserts, as noted, are manufactured from carbon steel meeting physical requirements of ASTM A283 GR D. To inhibit concrete seepage, all inserts (except spot inserts) are provided with closure strips and end caps or foam filler, unless otherwise requested. Most concrete inserts are available in stainless steel on special order. Consult factory for ordering information.

FINISHES

Cold-formed, standard-duty, light-duty and spot concrete inserts are available in:

- Perma-Green III (GR),
- Hot dipped galvanized (HG), conforming to ASTM A123 or A153;
- Pre-galvanized (PG), conforming to ASTM A653 GR 33
- Plain (PL).

Project: _____ Architect / Engineer: _____ Date: _____ Phone: _____ Contractor: _____ Address: _____ _____ Notes 1: _____ _____ Notes 2: _____ _____	Approval Stamp: _____ _____ _____
---	---