

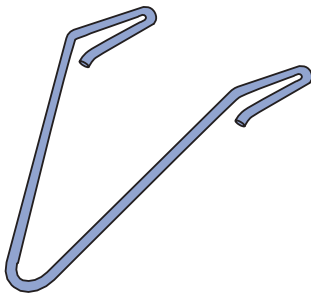

**P2865-10, -15, -20**

**HOLD-DOWN SPRINGS**



Finish: Plain

Part Number	A In (mm)	Wt/100 pcs Lbs (kg)
P2865-10	1 25	2 0.9
P2865-15	1 1/2 38	2 0.9
P2865-20	2 51	2 0.9

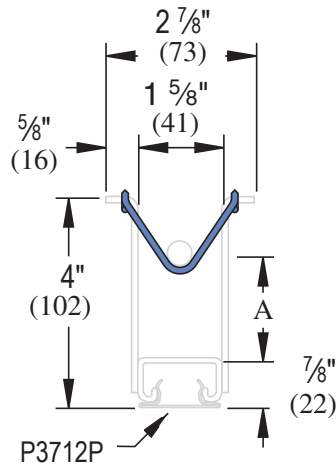

**MATERIAL**

Cold-formed inserts are manufactured from standard 12 gauge (2.7 mm) Unistrut channel sections conforming to ASTM A1011 SS GR 33 or ASTM A653 GR 33, unless otherwise noted. Hot-rolled inserts, as noted, are manufactured from carbon steel meeting physical requirements of ASTM A283 GR D. To inhibit concrete seepage, all inserts (except spot inserts) are provided with closure strips and end caps or foam filler, unless otherwise requested. Most concrete inserts are available in stainless steel on special order. Consult factory for ordering information.

**FINISHES**

Cold-formed, standard-duty, light-duty and spot concrete inserts are available in:

- Perma-Green III (GR),
- Hot dipped galvanized (HG), conforming to ASTM A123 or A153;
- Pre-galvanized (PG), conforming to ASTM A653 GR 33
- Plain (PL).

<b>Project:</b> _____ <b>Architect / Engineer:</b> _____ <b>Date:</b> _____ <b>Phone:</b> _____ <b>Contractor:</b> _____ <b>Address:</b> _____ _____ <b>Notes 1:</b> _____ _____ <b>Notes 2:</b> _____ _____	<b>Approval Stamp:</b>     
-----------------------------------------------------------------------------------------------------------------------------------------------------------------------------------------------------------------------------------------	--------------------------------------------