



P2476

PIPE ROLLER FOR 16" - 24" PIPE

Wt/100 pcs: 1046 Lbs (474.5 kg)

Chart for Dimension A

| Pipe Size | Insulation Thickness | | | | |
|-----------|----------------------|---------|---------|---------|---------|
| | 1 1/2" | 2" | 2 1/2" | 3" | 4" |
| In | In (mm) | In (mm) | In (mm) | In (mm) | In (mm) |
| 16 | - | - | 13 3/8 | 14 | 14 1/2 |
| 18 | 13 3/8 | 14 | 14 1/4 | 14 1/2 | 15 |
| 20 | 14 1/8 | 14 1/2 | 14 3/4 | 15 | 15 1/2 |
| 24 | 15 1/4 | 15 1/2 | 15 5/8 | 16 1/8 | 16 5/8 |
| | 387 | 394 | 403 | 410 | 422 |

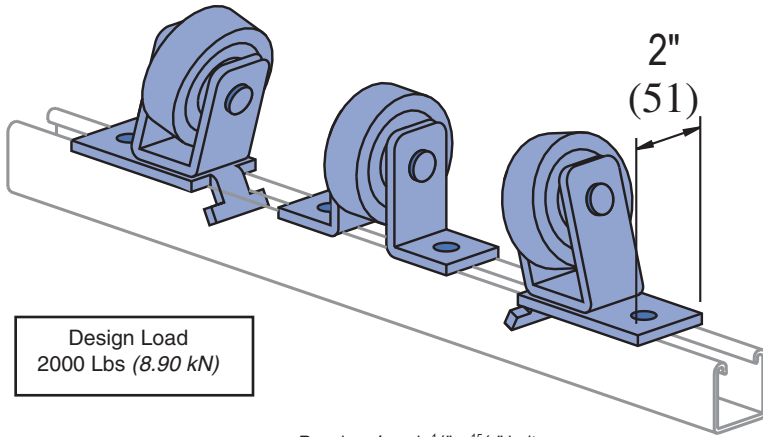

Design Load
2000 Lbs (8.90 kN)

- Requires 4 each 1/2" x 19/16" bolts and 1/2" channel nuts per assembly. Sold separately.

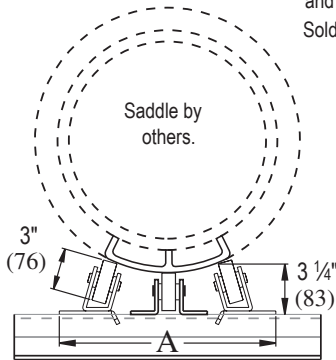

Material: Cast iron rollers.

Standard Dimensions for 1 5/8" (41 mm) width series channel fittings (Unless Otherwise Shown on Drawing)

Hole Diameter: 9/16" (14mm); Hole Spacing - From End: 13/16" (21 mm); Hole Spacing - On Center: 1 7/8" (48 mm); Width: 1 5/8" (41mm); Thickness: 1/4" (6mm)

MATERIAL

Unistrut pipe clamps, unless noted, are punch-press made from hot-rolled, pickled and oiled steel plates, strip or coil, and conform to ASTM specifications A1008, A575, A576, A635, or A36. The fitting steel also meets the physical requirements of ASTM A1011 SS GR 33. The pickling of the steel produces a smooth surface free from scale.

Many items are also available in stainless steel.

Consult factory for ordering information.

FINISHES

Pipe supports are available in:

- Electro-galvanized (EG), conforming to ASTM B633 Type III SC1
- Hot-dipped galvanized (HG), conforming to ASTM A123 or A153 (hardware)
- Perma-Green III (GR), and plain (PL).

Project: _____

Approval Stamp:

Architect / Engineer: _____

Date: _____ Phone: _____

Contractor: _____

Address: _____

Notes 1: _____

Notes 2: _____